

TRAFFIC ENGINEERING STUDY
Red Light Running Camera Evaluation Analysis
EB & WB US 290 Service Roads at FM 529
Jersey Village, Texas

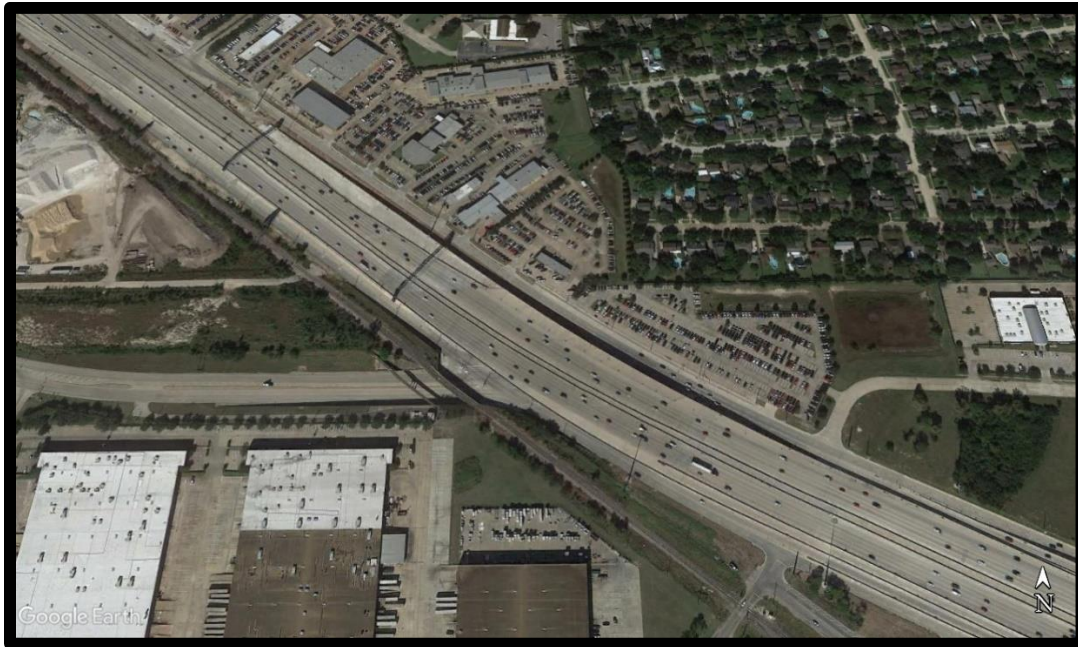

Prepared for:
City of Jersey Village
16401 Lakeview Drive
Jersey Village, Texas 77040

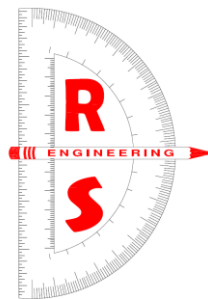

Prepared by:
REDS, LLC
Phoenix, Arizona
Texas TBPE Firm No. 19957

Engineer of Record:
Robert B Zaitooni, PE, PTOE
Texas Registration No. 98003
September 2018

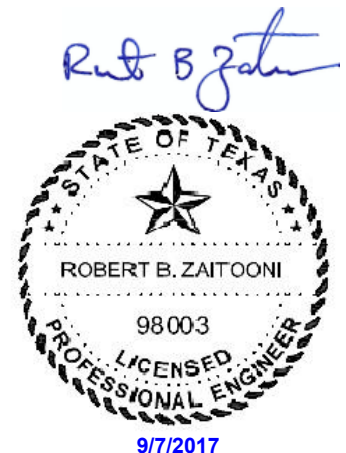

9/7/2017

TRAFFIC ENGINEERING STUDY
Red Light Running Camera Evaluation Analysis
EB & WB US 290 Service Roads at FM 529
Jersey Village, Texas

I. INTRODUCTION

PURPOSE

This traffic study is intended for the evaluation of potential safety deficiencies and installation of red light running counter-measures for the intersections of the eastbound and westbound US 290 Service Roads at FM 529, in the City of Jersey Village, Texas. The traffic engineering analysis consists of traffic data collection, qualitative assessment of the conditions, crash analysis, evaluation of signal operations and visibility, and evaluation of signal clearance intervals. Based on the analysis performed in this study, a series of effective counter-measures will be evaluated and recommended.

REQUIREMENTS

Texas Transportation Code Title 7 (Vehicles and Traffic) Subtitle I (Enforcement of Traffic Laws) Chapter 707 (Photographic Traffic Signal Enforcement System Section 707.003 (Installation and Operation of Photographic Traffic Signal Enforcement System), requires that the local authority shall conduct a traffic engineering study of the approach to determine whether, in addition to or as an alternative to the system, a design change to the approach or a change in the signalization of the intersection is likely to reduce the number of red light violations at the intersection.

Section 707.003, further requires that the intersection approach must be selected for the installation of a photographic traffic signal enforcement system based on traffic volume, the history of accidents at the approach, the number or frequency of red light violations at the intersection, and similar traffic engineering and safety criteria, without regard to the ethnic or socioeconomic characteristics of the area in which the approach is located.

In addition to the requirements of Section 707.003, the traffic study evaluated and documented the criteria outlined in the Texas Department of Transportation (TxDOT) Form 2296-RLC "Evaluation of the Need for Red Light Running Camera Engineering Analysis".

The United States Department of Transportation Federal Highway Administration (FHWA) developed an *Engineering Countermeasures to Reduce Red-Light Running Intersection Safety Brief (FHWA-SA-10-005)* that defines red-light running and provides potential engineering countermeasures to reducing red-light running. Some of the engineering countermeasures listed in the brief include:

- Improving Signal Visibility and Conspicuity,
- Increasing the Likelihood for stopping,
- Removing reasons for intentional violations and
- Eliminating the need to stop.



Figure 1. Intersection Location Map

II. INTERSECTION CONDITION ASSESSMENT

This section includes an assessment of the intersection operation and current field conditions as reviewed by a qualified registered professional traffic engineer.

As shown on Figure 1, FM 529 passes under US 290 (also known as Northwest Freeway) mainline; and intersects the EB & WB westbound US 290 Service Roads on north & south side of the freeway main line. Both EB & WB US 290 Service Road signals are operated with a single controller as shown on the signal schematic shown on Figure 2, provided by Texas DOT.

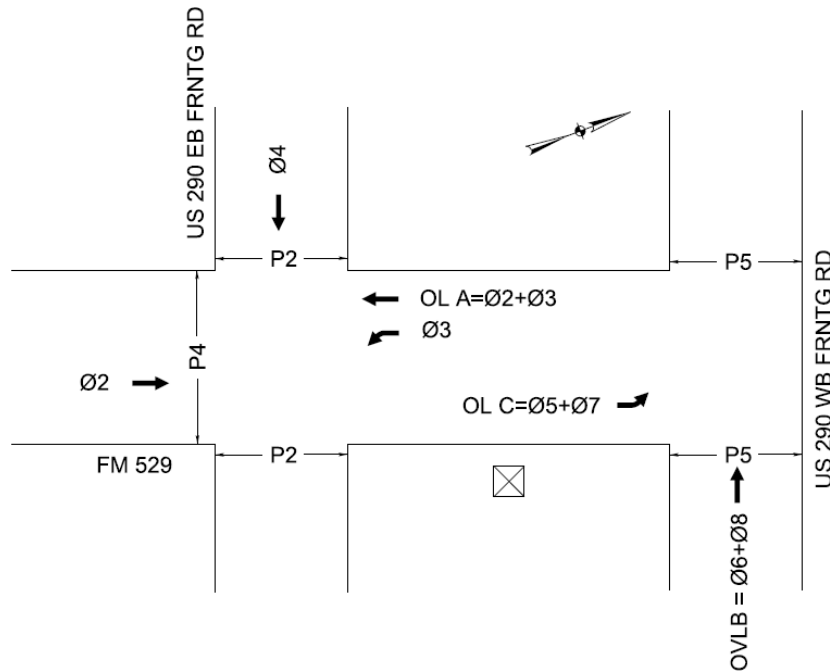

Figure 2. Traffic Signal Phasing

Section below is a summary of the intersection assessment including signal visibility, pavement condition, signal vehicle detection system, and signal operations.

WB US 290 Service Road Approach

The WB approach is located downstream of the US 290 westbound off ramp and consists of 3 lanes (2 through & 1 left turn) with curb and sidewalk as shown in Figure 2. FM 529 forms a “T” intersection with the WB approach.



Figure 3. WB US 290 Service Road Approach

Signal Visibility – Signal heads are visible from 1000'+ which is more than the MUTCD requirement of 390', as shown on Table 4D-2 below for posted speed of 40 mph. A “signal ahead” sign is installed at approximately 1000' back from the stop bar. The traffic signal heads are horizontal-mounted and include “tunnel visors” and “backplates” for maximum visibility.

85th-Percentile Speed	Minimum Sight Distance
20 mph	175 feet
25 mph	215 feet
30 mph	270 feet
35 mph	325 feet
40 mph	390 feet
45 mph	460 feet
50 mph	540 feet
55 mph	625 feet
60 mph	715 feet

Note: Distances in this table are derived from stopping sight distance plus an assumed queue length for shorter cycle lengths (60 to 75 seconds).

Table 1. 2009 MUTCD Table 4D-2

Pavement Conditions - A visual inspection of the pavement condition at the intersection showed no signs of significant wearing or cracking that could inhibit a driver's ability to stop while approaching the intersection. All required pavement marking (i.e. stop bar, lane lines, arrows, crosswalks) are aged but visible. Crosswalk striping on the west side of the intersection is missing. Signing is adequate and in conformance with MUTCD.

Vehicle Detectors – three (3) sets Loop sensors are installed in the pavement on this approach. 6' x 20' presence sensors are installed at the stop bar in all lanes, 6' x 6' advance pulse sensors are installed at approximately 110' from the stop bar and at 240' from stop bar. Pedestrian signal heads are installed for all permitted crossings.

Signal Operation – This signal is located approximately 0.41 miles from Senate Avenue signal, along WB US 290 Service Road. Arrival at the signal is mostly random due to the freeway ramp merge 500' back. Long queue of vehicles were observed for several cycles in the morning, back to the freeway ramp. Signal phasing does not appear to be a contributing factor to red light running, however, signal timing seems to cause unnecessary delays for the approach.



Figure 4. Queuing on WB US 290 SR Approach

EB US 290 Service Road Approach

The EB approach consists of 4 lanes (1 shared through & left, 2 through, 1 right turn) with curb and sidewalk as shown in Figure 5.

Signal Visibility – As the signal is located on the bottom of a vertical down-grade, signal heads can get blocked by vehicles ahead, from approximately 900' and farther. Once passed the 900' mark, signal head become visible. 900' sight visibility exceeds the MUTCD requirement of 390', as shown on Table 4D-2 below for posted speed of 40 mph. The traffic signal heads are horizontal-mounted and include "tunnel visors" and "backplates" for maximum visibility. A "signal ahead" sign is installed at 750' from stop bar.



Figure 5. EB US 290 Service Road Approach

Pavement Conditions - A visual inspection of the pavement condition at the intersection showed no signs of significant wearing or cracking that could inhibit a driver's ability to stop while approaching the intersection. All required pavement marking (i.e. stop bar, lane lines, arrows, crosswalks) are present. However, the color contrast between the concrete surface and white paint is very low but visible. Signage is adequate and in conformance with MUTCD.

Vehicle Detectors – three (3) sets Loop sensors are installed in the pavement on this approach. 6' x 20' presence sensors are installed at the stop bar in all lanes, and 2 sets of 6' x 6' advance pulse sensors are installed at approximately 110' and at approximately 240' from stop bar. Pedestrian signal heads are installed for all permitted crossings.

Signal Operation – Arrival is generally in random due to separation distance of approximately 1.2 miles from previous signal at Jones Road. The signal phasing and operation do not appear to be a contributing factor to red light running. Observed traveling speeds are higher than the posted limits.

NB FM 529 Approach

This approach to the intersection has 4 lanes (2 through & 2 right turn) and posted speed of 45 mph. The profile of the approach is on a long down-grade with overhead structures which limit sight visibility to the signals, as depicted on Figure 6 & 7.



Figure 6. NB Senate Avenue Approach

Signal Visibility – The vertical down-grade in conjunction with 2 bridge overpasses on the approach, block sight to the signal heads. The signal heads are visible from approximately 430', which is less than 460' requirements for 45 mph. This route is heavily used by trucks which further restrict visibility on the approach. There is no "signal ahead" sign for the approach and installation is recommend as soon as possible.



Figure 7. NB FM 529 Approach

Pavement Conditions - A visual inspection of the pavement condition at the intersection showed no signs of significant wearing or cracking that could inhibit a driver's ability to stop while approaching the intersection. All required pavement marking (i.e. stop bar, lane lines, arrows, crosswalks) are visible but the low contrast between the lighter color surface and white pavement marking effect the visibility. Signing is adequate and in conformance with the requirements of MUTCD.

Vehicle Detectors – 2 sets of 6' x 20' vehicle loop sensors in presence mode are installed in all lanes and functioning.

Signal Operation – Arrival at the signal is random. The signal phasing and operation do not appear to be a contributing factor to red light running. However, longer than necessary delays caused by inefficient timings, may be influencing erratic behavior by the motorists. Recommend evaluation of the timings to reduce delays.

III. TRAFFIC VOLUMES

24-hour directional traffic volume data were collected on Wednesday, August 29, 2018; for the approaches of the intersections. Figures 8-10 depict the daily and hourly volumes, and the peaking characteristics of the intersection approaches. Copies of the actual volume data are provided in the Appendix C of this report. As depicted, data indicates a distinct high morning peak in the EB US 290 Service Road between the hours of 7:00 to 8:00 AM. The afternoon high peak occurs between 4:00 to 5:00 PM on WB US 290 Service Road. Northbound FM 529 has 2 distinct peaks, morning between 6:00-7:00 AM and afternoon between 4:00 to 5:00 PM. Although truck volume data was not collected, the relatively high percentage were observed using FM 529 from the light industrial area near the intersection.

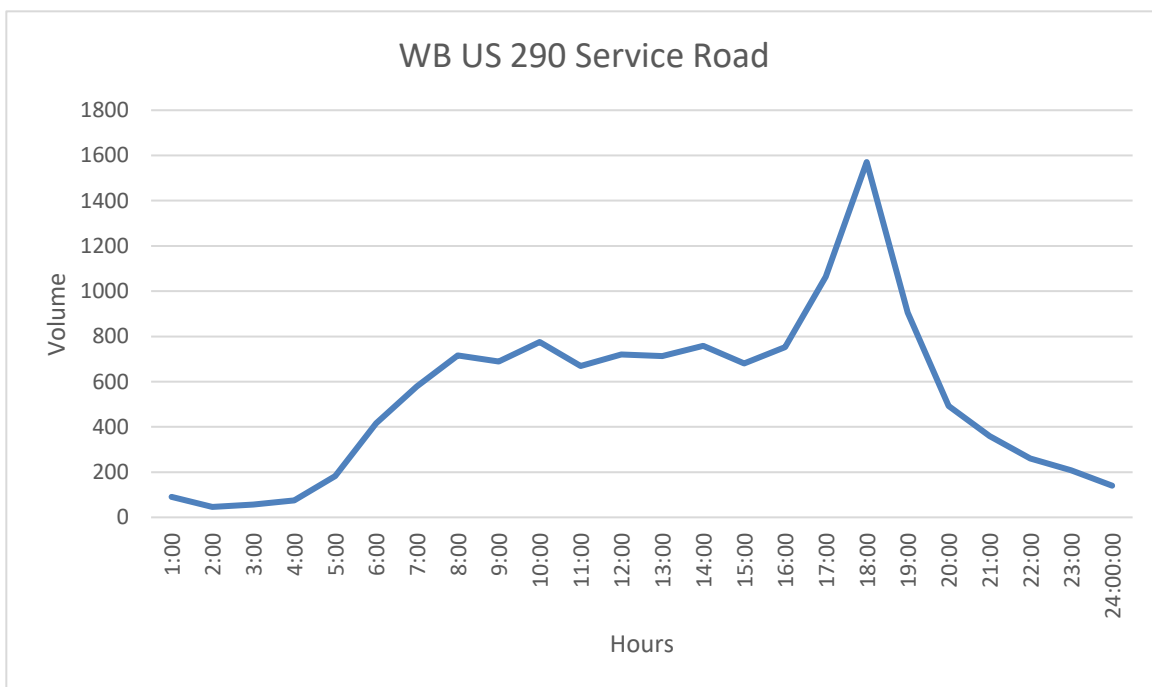

Figure 8. WB US 290 Service Road Daily Traffic Flow

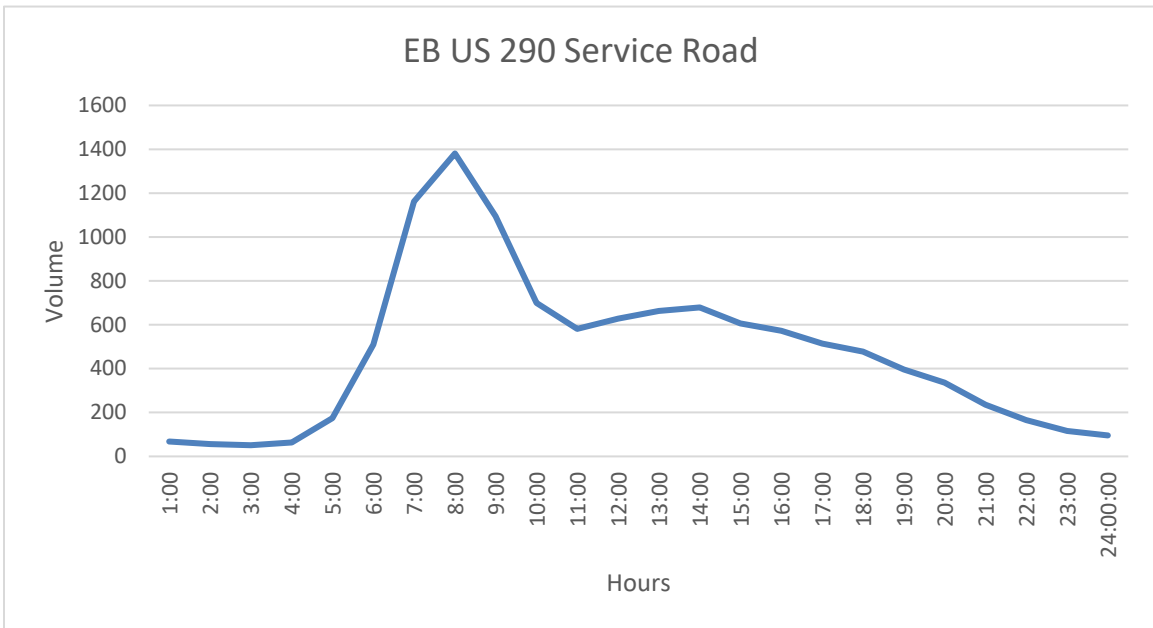

Figure 9. EB US 290 Service Road Daily Traffic Flow

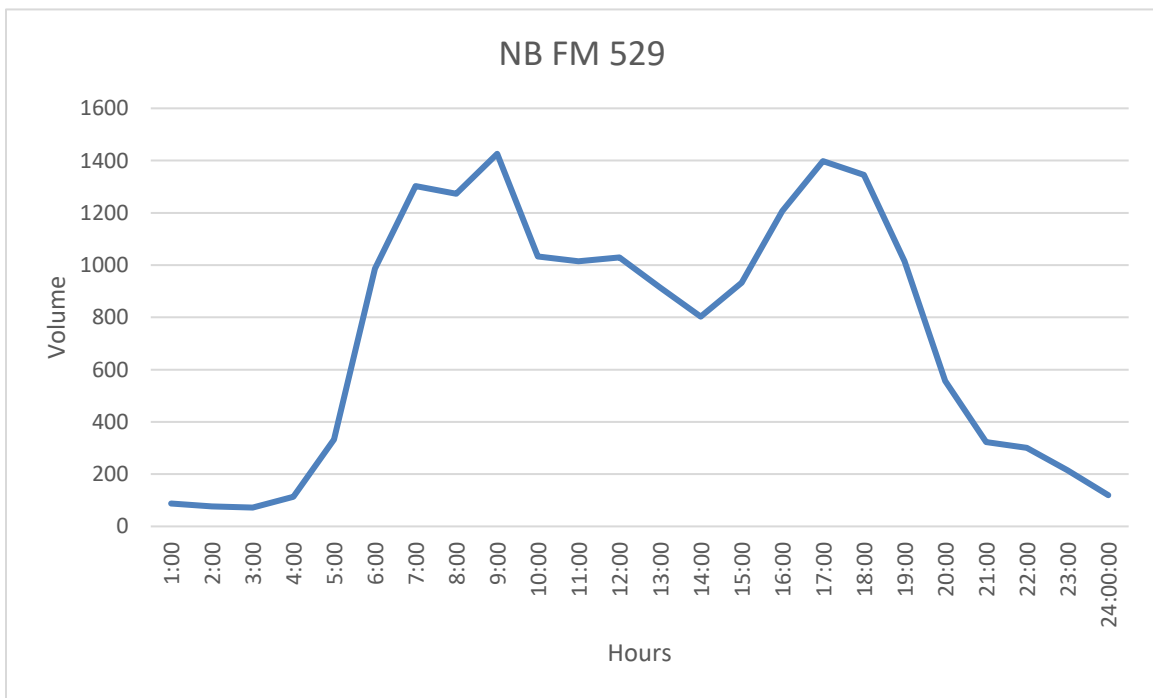

Figure 10. NB Senate Avenue Daily Traffic Flow

IV. CRASH ANALYSIS

City of Jersey Village Police Department (JVPD) compiled and provided an 18-month crash history for the intersection approaches by type and severity, for the period 1/2017 through 8/2018. Table 2 below contains a summary of the crash data. Detail summaries provided by JVPD are provided in the Appendix B of this report.

Approach	Total	Right Angle	Rear End	Other	Fatal	Injury Crash	RLC Related
NB FM 529	11	6	5	0	0	1	0
EB US 290 SR	7	3	4	0	0	2	2
WB US 290 SR	8	7	1	0	0	1	0
Total All Crashes	26	16	10	0	0	4	2

Table 2. 18-Month Crash Summary (1/2017-8/2018, JVPD)

The analysis of the data suggests a high pattern of “right-angle” type crashes on all 3 approaches of the intersection. Northbound FM 529 approach has the highest number of crashes, with 55% right-angle crashes which is generally attributed to driver’s failure to obey traffic control device and typically susceptible to correction by installation of red light running counter-measures. Given the high number of right-angle crashes, all approaches of the intersection are expected to be good candidates for consideration.

V. ENFORCEMENT DATA

City of Jersey Village provided records of enforcement activities for the most recent 18-month period (January 1, 2017 through August 20, 2018). Records indicate that a total of 5,671 citations were issued for the 3-mile section of EB & WB US 290 Service Road, from Hilcrest Road to N Eldridge Parkway.

For the intersection of EB & WB US 290 Service Road at FM 529, a total of 789 citations were issued which included 352 in the eastbound direction and 437 in the westbound direction. The totals include 16 “red light running” citations, 5 in the eastbound direction and 11 in the westbound direction. Some of the reasons for citations included the following:

- Speeding
- Unsafe lane change
- Turn from improper lane

VI. SIGNAL CLEARANCE INTERVALS

Traffic existing signal timing data was provided by TXDOT and is shown in Table 3. Appendix D contains the full timing data document for the intersection.

PHASES	1	2	3	4	5	6	7	8
Minimum Green	0	10	5	10	5	1	3	10
Passage	0.0	2.0	2.0	2.0	2.0	2.0	2.0	2.0
Maximum 1	0	45	60	60	35	7	50	70
Maximum 2	0	55	60	60	40	7	50	70
Yellow Change	3.0	4.3	4.3	4.3	4.3	4.3	4.3	4.3
Red Clearance	0.0	1.6	1.6	2.9	1.2	2.9	1.2	2.9

Table 3. Existing Signal Timing (Provided by TXDOT)

The calculated yellow and all-red clearance times were obtained from the *ITE Traffic Engineering Handbook (5th Edition)* using Table 13-3 “Nominal Values for Change + Clearance Interval Time”. The Yellow Change Interval time + Red Clearance Interval time includes a reaction time, a deceleration element, and an intersection clearing time, using the following equations:

$$Y = t + \frac{1.47v}{2(a + Gg)} \qquad R = \frac{W + L}{1.47v}$$

Where:

- Y= yellow change interval (sec)
- R= all-red interval (sec)
- t= perception-reaction time (1 sec)
- v= approach speed (ft/sec)
- a= deceleration rate (10 ft/sec²)
- g=acceleration rate in response to the onset of a yellow indication. (ft/sec²)
- G= approach grade, with uphill positive and downhill negative (percent grade / 100)
- W= width of intersection from near curb line to far curb line (ft)
- L=length of vehicle (20 ft)

The calculated yellow and all-red intervals are provided in Table 4. It should be noted that for positive approach grades, 0% slope was assumed for the calculations.

Approach	Approach Grade %	Approach Speed MPH	W (Distance), Ft	Calculated Yellow Interval (Sec)	All-Red Interval (Sec)
NB FM 529 (Ø2)	-1.0%	45	90	4.5	1.7
EB US 290 Service Rd (Ø4)	-1.5%	40	135	4.1	2.7
WB US 290 Service Rd (OVLB= Ø6+Ø8)	0.0%	40	90	4.0	2.0

Table 4. Calculated Yellow & All-Red Intervals

Approach	Yellow Interval (Sec)		All-Red Interval (Sec)	
	Existing	Calculated	Existing	Calculated
NB FM 529 (Ø2)	4.7	4.5	1.6	1.7
EB US 290 Service Rd (Ø4)	4.3	4.1	2.9	2.7
WB US 290 Service Rd (OVLB= Ø6+Ø8)	4.3	4.0	2.9	2.0

Table 5. Yellow & All-Red Interval Comparison

Overall, the existing yellow intervals are higher and more conservative than the calculated values and shall remain in effect. The existing all-red intervals are consistent with the calculated values. No further changes are recommended.

VII. TXDOT ENGINEERING ANALYSIS EVALUATION FORM

The Texas Department of Transportation (TxDOT) has developed an engineering analysis form titled “Evaluation of the Need for Red Light Running Camera Engineering Analysis” which is also referred to as Form 2296-RLC. The evaluation analysis worksheets, included in Appendix A, include sections for information on intersection and signal data, signal timing and traffic data, crash and enforcement data, and other supporting information.

VIII. POTENTIAL ENGINEERING COUNTERMEASURES

As discussed previously, the Texas Transportation Code Title 7 (Vehicles and Traffic) Subtitle I (Enforcement of Traffic Laws) Chapter 707 (Photographic Traffic Signal Enforcement System Section 707.003 (Installation and Operation of Photographic Traffic Signal Enforcement System), requires that the local authority shall conduct a traffic engineering study of the approach to determine whether, in addition to or as an alternative to the system, a design change to the approach or a change in the signalization of the intersection is likely to reduce the number of red light violations at the intersection.

Based on the application of the procedures recommended by The Institute of Transportation Engineers (ITE) and the Federal Highway Administration (FHWA) publication, Table 6 below summarizes the countermeasures that can be considered under each of the countermeasure groupings identified above. These engineering countermeasures are based on a driver characteristic called the “unintentional violator.” This type of driver may be incapable of stopping or may be inattentive while approaching the intersection due to poor judgement by the driver or in the design or operation of the intersection. A second type of driver characteristic is the “intentional violator” who, based on his/her judgement, knows they may violate the signal yet proceeds through the intersection anyway. This type of driver is most affected by enforcement countermeasures, while unintentional red-light runners are most affected by engineering countermeasures.

Improvement category	Intersection Approaches		
	NB FM 529	EB US 290 SR	WB US 290 SR
Improve Signal Visibility/Conspicuity			
Signal for Each Approach Through Lane	Existing OK	Existing OK	Existing OK
Install Backplates	Existing OK	Existing OK	Existing OK
Modify Placement of Signal Heads	Add Warning	Existing OK	Existing OK
Increase Size of Signal Displays	Existing OK	Existing OK	Existing OK
Install Programmable Signal/ Visors or Louvers	Existing/Visors	Existing/Visors	Existing/Visors
Install LED Signal Lenses	Not Recommended	Not Recommended	Not Recommended
Increase the Likelihood for Stopping			
Install Signal Ahead Signs	Install Multiple New	Existing at 750'	Existing at 1000'
Install Transverse Rumble Strips	Not Recommended	Not Recommended	Not Recommended
Install Activated Advance Warning Flashers	Consider	Not Recommended	Not Recommended
Improve Pavement Surface Condition	Not Recommended	Not Recommended	Not Recommended
Remove Reasons for Intentional Violations			
Adjust Yellow Change Interval	Existing OK	Existing OK	Existing OK
Provide or Adjust All-Red Clearance Interval	Existing OK	Existing OK	Existing OK
Adjust Signal Cycle Length	Evaluate	Evaluate	Evaluate
Provide Dilemma Zone Protection	Not Recommended	Existing	Not Recommended
Eliminate the Need to Stop			
Coordinate Signal Operation	Existing OK	Existing OK	Existing OK
Remove Unwarranted Signals	N/A	N/A	N/A
Construct a Roundabout	Not Recommended	Not Recommended	Not Recommended

Source: USDOT Federal Highway Administration

Table 6. Summary of Countermeasures for Reducing Red-Light Running

IX. CONCLUSIONS & RECOMMENDATIONS

The analysis determined a high concentration of “right-angle” type crashes for US 290 Service Road approaches with FM 529, on both sides of the Northwest Freeway. The “right-angle” crash type at signalized intersections are generally attributed to failure to obey the traffic control device. The enforcement data provided by JVPD illustrates that although there is a high level of enforcement, a persistent violation pattern remains. Implementation of a red-light-running cameras has been shown to significantly reduce the “right-angle” crash frequency at signalized intersections, specifically through the enforcement of “intentional violators”. Other red-light running counter-measures, designed to improve the conspicuity of the traffic signal, can also be considered to reduce the unintentional violations.

In conclusion, installation of red light running enforcement cameras on all approaches will reduce the incidents of red light running and will enhance the overall safety of the intersection. Other potentially effective red light running countermeasure listed on Table 6, will also further enhance the safety by curtailing violations. A summary of recommended improvements is provided below:

NB Senate Avenue

- Install 2 “signal ahead” signs, one on shoulder side and one in the median, prior to the structures on this approach. Evaluate the need for flashing warning devices in advance of the intersection.
- Evaluate the signal timing to reduce un-necessary delays that influence driver behavior.
- Install a red light running enforcement camera.

EB US 290 Service Road

- Install a red light running enforcement camera.
- Evaluate the signal timing to reduce un-necessary delays that influence driver behavior.

WB US 290 Service Road

- Install crosswalk on west side of the intersection.
- Evaluate the signal timing to address frequent queuing and reduce un-necessary delays that influence driver behavior.
- Install a red light running enforcement camera.

APPENDIX INDEX

Appendix A TxDOT Engineering Analysis Worksheet (Form 2296RLC)

Appendix C Crash Data

Appendix C Traffic Volumes

Appendix D Traffic Signal Timing Sheets

Appendix E TxDOT Traffic Signal Plans

APPENDIX A
TxDOT ENGINEERING ANALYSIS WORKSHEET
(Form 2296RLC)



Evaluation of the Need for Red Light Running Cameras Engineering Analysis

City: Jersey Village County: Harris

Intersection: EB & WB US 290 Service Roads at FM 529

A. Intersection and Signal Data

1. Signal Visibility

a. Minimum Sight Distance to Signal

Approach	Grade	Speed Limit (MPH)	Measured (ft.)	Required (ft.)*
WB US 290 SR	0%	40	1000+	390
NB Senate Ave	-1.0%	45	430	460
EB US 290 SR	-1.5%	40	900+	390

- See TMUTCD Table 4D-2 for minimum sight distance requirements

- b. Are "SIGNAL AHEAD" warning signs present? Yes No
 Yes- on EB & WB US 290SR
 No – on NB FM 529
- c. Are "SIGNAL AHEAD" warning signs needed? Yes No
 Needed only on NB & SB Senate Avenue
- d. Are other warning signs present in the vicinity of the intersection?
 Yes No

Explain: _____.

e. Information on Signal Heads

Approach	Lens Size	Lens Type (LED or Bulb)	Back Plates (Y or N)	Retroreflective Border (Y or N)
WB US 290 SR	12"	Bulb	Y	N
NB FM 529	12"	Bulb	Y	N
EB US 290 SR	12"	Bulb	Y	N

2. Pavement and Marking Data

- a. Are stop bars in "good" condition? Yes No
 Explain: The stop bars on all approaches are visible but the color contrast between the light color concrete pavement and white paint provides lesser target value.
- b. Are lanes "clearly" visible? Yes No
 Explain:
- c. Are crosswalks "clearly" marked? Yes No
 Explain: crosswalk on west side of WB US290 SR is missing. Crosswalks are visible but the color contrast between light color concrete pavement and paint, provides lesser target value
- d. What is the pavement condition (ruts, potholes, cracking, etc.)?
 Good Explain:
 Fair Explain:
 Poor Explain:

e. Do pavement surface treatments exist (rumble strips, texturing, pavers, etc.)?

Yes Explain:

No

3. Provide diagram of intersection including: pavement markings, width of lanes and medians,

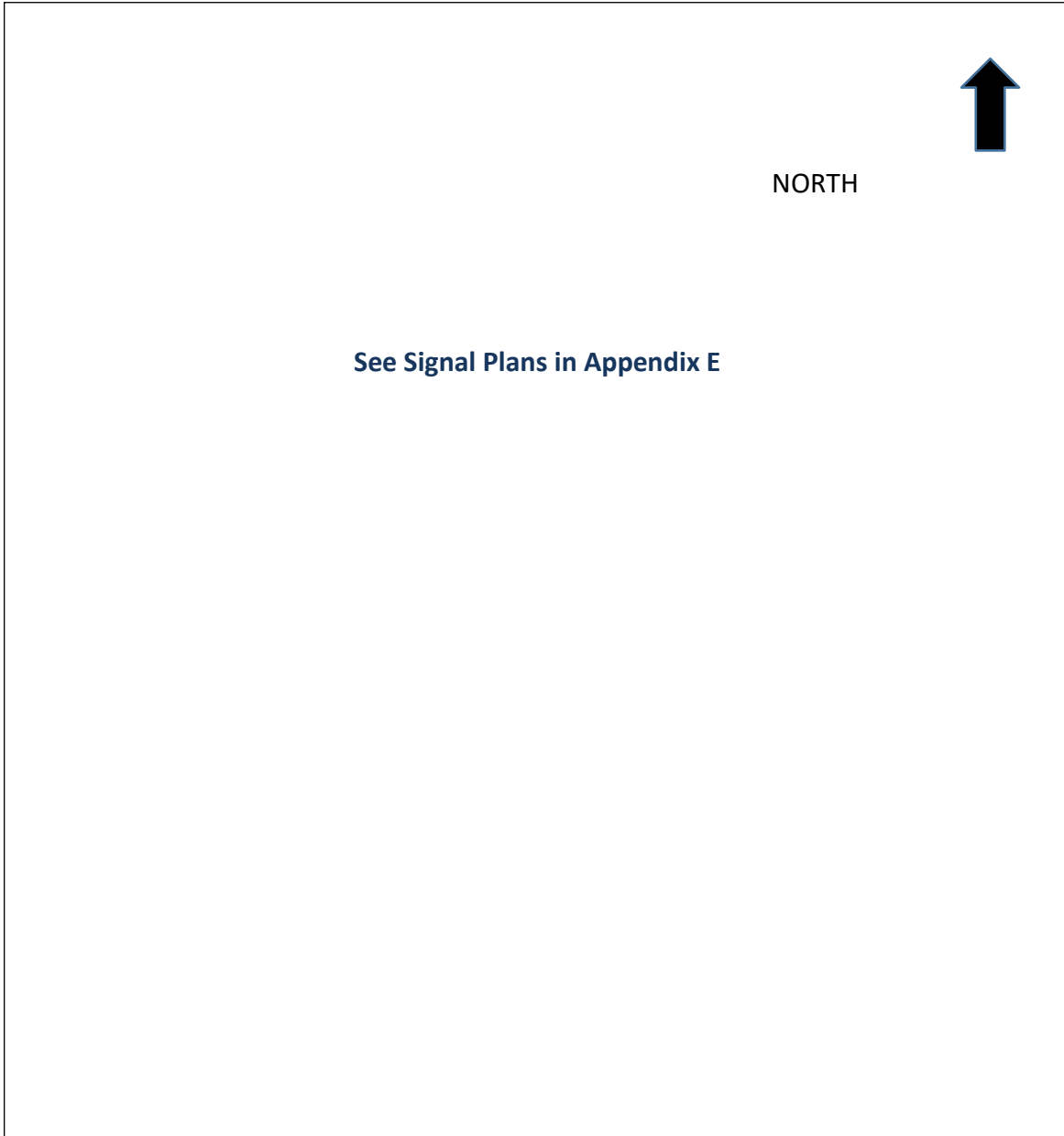

location of signal heads and signs, locations of loops/detectors, and grades.

See signal plans provided by TxDOT in Appendix E

B. Signal Timing and Traffic Data

1. Clearance Intervals

Approach	Posted Speed Limit	Grade	Width of Intersection	Yellow Interval		All Red Interval	
				Existing	Calculated*	Existing	Calculated*
WB US 290 SR	40	0%	90'	4.3	4.1	2.9	2.7
NB Senate Ave	45	-1.0%	90'	4.7	4.5	1.6	1.7
EB US 290 SR	40	-1.5%	135'	4.3	4.1	2.9	2.7

- Reference ITE for calculation of clearance intervals

2. Include existing controller settings for each phase and each time-of-day. Information should include applicable settings such as minimum green, max 1 & 2, passage, minimum gap/ext., protected-permissive, lead-lag, yellow and all red, walk and ped clearance time, recall settings, offsets, cycle length, etc. Include analysis of peak hour conditions and a determination of whether signal timings are contributing to red-light running problems. See controller timings provided by TxDOT in Appendix D

a. Does signal timing or phasing factor in as a possible contributor to red light running at this intersection?

Yes Explain:

No

b. List comments or recommendations on potential signal timing or phasing changes:

No phasing or changes are recommended. Observed excessive and unwarranted delays. Recommend evaluation of the signal timings to reduce queues and delays.

3. Vehicle Detection Data

Approach	Detection Type (loop, video, etc.)	Detector Location (measured from stop bar)
WB US 290 SR	Loop	6' x 20' at stop bar, 6'x6' loops at 110' & 240'
NB FM 529	Loop	2 sets of 6' x 20' at stop bar
EB US 290 SR	Loop	6' x 20' at stop bar, 6'x6' loops at 110' & 240'

4. Traffic Volume Data

Approach	Daily Volumes		Peak Hour Volumes	
	Total	Heavy Vehicles	Total	Heavy Vehicles
WB US 290 SR	12922	-	1571	-
NB FM 529	17,840	Not measured but heavy	1426	Not measured but heavy
EB US 290 SR	11327	-	11327	-

C. Crash and Enforcement Data

1. 18 Months of "Before" Crash Data

Approach	Collision Type	Total	Number of Injury Crashes	Number of Fatal Crashes	Crashes Associated with Red Light Running
NB FM 529	Rear End	5	0	0	0
	Angle	6	0	0	0
	Head-on	0	0	0	0
	Pedestrian	0	0	0	0
	Pedal cyclist	0	0	0	0
	Other	0	0	0	0
	Total		11	1	0
EB US 290 SR	Rear End	3	0	0	0
	Angle	4	2	0	2
	Head-on	0	0	0	0
	Pedestrian	0	0	0	0
	Pedal cyclist	0	0	0	0
	Other	0	0	0	0
	Total		7	2	0
WB US 290 SR	Rear End	1	0	0	0
	Angle	7	1	0	0
	Head-on	0	0	0	0
	Pedestrian	0	0	0	0
	Pedal cyclist	0	0	0	0
	Other	0	0	0	0
	Total		8	1	0
	Rear End				
	Angle				
	Head-on				
	Pedestrian				
	Pedal cyclist				
	Other				
	Total				

2. Violation Rate

a. Number of red light running citations per year issued by law enforcement Number: Total 789 Citations on US 290 SR (352 EB & 437 WB) including 16 citations for running red light(5 EB & 11 WB)
 Year: Jan. 1, 2017 – Aug. 20, 2018

b. Observed Violations: None Observed Date:
 Time Period:

Approach	Traffic Volume	Number of Violations

3. Enforcement and Operational Issues

a. Describe the difficulty experienced by law enforcement officers in patrol cars or on foot in apprehending violators. Law enforcement resources are limited. This is a high congestion during morning and afternoon peak periods. Speed are also higher than posted. Enforcement level has been high with 789 citations issued in 18-month period, but, red light running remains a concern with high level of "right-angle" crash types.

b. Describe the ability of law enforcement officers to apprehend violators safely within a reasonable distance from the violation. Law enforcement resources are limited for consistent enforcement. This is a congested area during AM & PM peak periods. Long enforcement activities affects the congestion level and impacts freeway ramp operation.

c. Are pedestrians at risk due to violations? Yes No

Explain:

Number of pedestrians per hour: None Observed

Pedestrian crosswalk provided? Yes No

Crosswalk on WB US 290 SR on west side are missing.

d. Have there been any changes to the operations of the intersection (signal timing, restriping, increased enforcement, etc.) with the past three years. Yes. TxDOT recently completed intersection improvements at the intersections on both side of the freeway.

D. Other Supporting Information:

See traffic study for more details.

APPENDIX B
CRASH DATA

2018 RLC YEAR TOTAL'S	Total Int. CRASHES	RLC RELATED CRASHES	RLC INJ CRASHES	RL RELATED INJ	NON RLR CRASHES	NON RLC REL.INJ CRA.	NON RLC REL. INJ.	RLR FATAL CRASHES	RLC FATAL CRASHES	NON RLR FATALITIES	NON RLR FATALITES
JV01 SB SENATE @ WBSR	0	0	0	0	0	0	0	0	0	0	0
JV02 NBSenate @ EBSR	5	1	1	2	4	0	0	0	0	0	0
JV03 EBSR @ SENATE	3	0	0	0	3	1	1	0	0	0	0
JV04 WBSR @ SENATE	5	1	1	2	4	0	0	0	0	0	0
JV05 SB JONES @ WBSR	8	0	0	0	8	1	1	0	0	0	0
JV06 WBSR @ JONES	7	0	0	0	7	0	0	0	0	0	0
JV07 EBSR @ JONES	7	2	2	3	5	0	0	0	0	0	0
JV08 EBSR @ FM 529	4	1	1	1	3	1	2	0	0	0	0
JV09 WBSR @ FM 529	4	0	0	0	4	0	0	0	0	0	0
JV13 WBSR @ WEST RD	8	5	2	5	3	1	1	0	0	0	0
JV18 NB FM 529 @ EBSR	2	0	0	0	1	0	0	0	0	0	0
	53	10	7	13	42	4	5	0	0	0	0

Source: JVPD

2017 RLC YEAR TOTAL'S	Total Int. CRASHES	RLC RELATED CRASHES	RLC INJ CRASHES	RL RELATED INJ	NON RLR CRASHES	NON RLC REL.INJ CRASHES	NON RLC REL. INJ.	RLR FATAL CRASHES	RLC REL. FATALITIES	NON RLR FATAL CRA	NON RLR FATALITES
JV01 SB SENATE @ WBSR	1	0	0	0	1	0	0	0	0	0	0
JV02 NB Senate @ EBSR	9	3	1	1	6	1	1	0	0	0	0
JV03 EBSR @ SENATE	6	0	1	2	6	0	0	0	0	0	0
JV04 WBSR @ SENATE	5	1	0	0	4	0	0	0	0	0	0
JV05 SB JONES @ WBSR	6	0	0	0	6	1	1	0	0	0	0
JV06 WBSR @ JONES	8	1	0	0	7	0	0	0	0	0	0
JV07 EBSR @ JONES	10	1	0	0	9	1	1	0	0	0	0
JV08 EBSR @ FM 529	3	3	1	1	0	0	0	0	0	0	0
JV09 WBSR @ FM 529	5	0	1	1	5	0	0	0	0	0	0
JV13 WBSR @ WEST RD	14	7	2	3	7	0	0	0	0	0	0
JV18 NB FM 529 @ EBSR	9	1	0	0	8	1	1	0	0	0	0
	76	17	6	8	59	4	4	0	0	0	0

Source: JVPD

APPENDIX C
TRAFFIC VOLUMES

GRAM Traffic Counting, Inc

1506 Festival Houston, Texas 77062
832-752-3303 or 888-315-6141

Site Code: 6 NB
Station ID: 1605
FM 529 south of eb US 290 Service Rd
Jersey Village, Texas
Latitude: 0' 0.0000 Undefined

Start Time	29-Aug-18 Wed	NB		Hour Totals	
		Morning	Afternoon	Morning	Afternoon
12:00		26	253		
12:15		21	231		
12:30		24	232		
12:45		16	198	87	914
01:00		13	195		
01:15		18	197		
01:30		26	220		
01:45		19	191	76	803
02:00		20	200		
02:15		11	249		
02:30		23	269		
02:45		18	215	72	933
03:00		23	317		
03:15		25	235		
03:30		34	335		
03:45		31	320	113	1207
04:00		37	386		
04:15		59	284		
04:30		96	400		
04:45		141	328	333	1398
05:00		155	428		
05:15		211	311		
05:30		301	335		
05:45		319	271	986	1345
06:00		350	292		
06:15		324	262		
06:30		311	288		
06:45		318	173	1303	1015
07:00		304	147		
07:15		305	155		
07:30		334	143		
07:45		294	112	1237	557
08:00		340	74		
08:15		366	78		
08:30		347	89		
08:45		373	82	1426	323
09:00		282	87		
09:15		246	94		
09:30		228	64		
09:45		277	56	1033	301
10:00		281	74		
10:15		286	66		
10:30		238	45		
10:45		210	30	1015	215
11:00		268	32		
11:15		262	33		
11:30		278	34		
11:45		221	20	1029	119
Total		8710	9130		
Percent		48.8%	51.2%		
Grand Total		8710	9130		
Percent		48.8%	51.2%		
ADT		ADT 17,840		AAADT 17,840	

GRAM Traffic Counting, Inc

1506 Festival Houston, Texas 77062
832-752-3303 or 888-315-6141

Site Code: 6 SB
Station ID: 1605
FM 529 south of eb US 290 Service Rd
Jersey Village, Texas
Latitude: 0' 0.0000 Undefined

Start Time	29-Aug-18 Wed	SB		Hour Totals	
		Morning	Afternoon	Morning	Afternoon
12:00		30	210		
12:15		27	183		
12:30		25	162		
12:45		18	202	100	757
01:00		15	185		
01:15		15	180		
01:30		15	194		
01:45		14	196	59	755
02:00		18	164		
02:15		12	186		
02:30		13	210		
02:45		27	270	70	830
03:00		16	226		
03:15		11	263		
03:30		28	287		
03:45		33	330	88	1106
04:00		27	315		
04:15		54	309		
04:30		105	383		
04:45		101	332	287	1339
05:00		113	297		
05:15		180	343		
05:30		329	308		
05:45		352	367	974	1315
06:00		150	328		
06:15		224	299		
06:30		222	249		
06:45		258	247	854	1123
07:00		218	204		
07:15		196	171		
07:30		240	197		
07:45		244	140	898	712
08:00		209	143		
08:15		185	126		
08:30		208	112		
08:45		197	126	799	507
09:00		165	121		
09:15		145	99		
09:30		192	82		
09:45		164	98	666	400
10:00		177	89		
10:15		184	81		
10:30		166	66		
10:45		151	52	678	288
11:00		187	76		
11:15		163	42		
11:30		153	47		
11:45		177	39	680	204
Total		6153	9336		
Percent		39.7%	60.3%		
Grand Total		6153	9336		
Percent		39.7%	60.3%		
ADT		ADT 15,489		AADT 15,489	

GRAM Traffic Counting, Inc

1506 Festival Houston, Texas 77062
832-752-3303 or 888-315-6141

Site Code: 5
Station ID: 1613
EB US 290 Service Rd west of FM 529
Jersey Village, Texas
Latitude: 0' 0.0000 Undefined

Start Time	29-Aug-18 Wed	EB		Hour Totals	
		Morning	Afternoon	Morning	Afternoon
12:00		26	160		
12:15		15	179		
12:30		16	160		
12:45		11	164	68	663
01:00		13	163		
01:15		17	195		
01:30		16	181		
01:45		10	140	56	679
02:00		15	161		
02:15		12	147		
02:30		15	146		
02:45		9	152	51	606
03:00		12	146		
03:15		10	129		
03:30		24	158		
03:45		18	139	64	572
04:00		10	137		
04:15		35	153		
04:30		61	93		
04:45		68	131	174	514
05:00		64	97		
05:15		88	152		
05:30		168	113		
05:45		190	116	510	478
06:00		221	101		
06:15		277	91		
06:30		281	106		
06:45		383	98	1162	396
07:00		305	102		
07:15		324	64		
07:30		396	89		
07:45		356	81	1381	336
08:00		328	66		
08:15		289	66		
08:30		239	60		
08:45		239	43	1095	235
09:00		191	54		
09:15		197	35		
09:30		154	41		
09:45		158	36	700	166
10:00		117	34		
10:15		137	33		
10:30		168	29		
10:45		160	20	582	116
11:00		152	31		
11:15		157	25		
11:30		141	16		
11:45		178	23	628	95
Total		6471	4856		
Percent		57.1%	42.9%		
Grand Total		6471	4856		
Percent		57.1%	42.9%		

ADT

ADT 11,327

AADT 11,327

GRAM Traffic Counting, Inc

1506 Festival Houston, Texas 77062
832-752-3303 or 888-315-6141

Site Code: 8
Station ID: 1615
WB US 290 Service Rd east of Senate Av
Jersey Village, Texas
Latitude: 0' 0.0000 Undefined

Start Time	29-Aug-18 Wed	WB		Hour Totals	
		Morning	Afternoon	Morning	Afternoon
12:00		24	181		
12:15		31	189		
12:30		24	158		
12:45		11	185	90	713
01:00		9	183		
01:15		20	201		
01:30		9	193		
01:45		8	182	46	759
02:00		18	155		
02:15		10	175		
02:30		9	196		
02:45		19	154	56	680
03:00		21	169		
03:15		12	194		
03:30		22	173		
03:45		20	217	75	753
04:00		27	224		
04:15		47	232		
04:30		58	299		
04:45		51	309	183	1064
05:00		61	354		
05:15		83	444		
05:30		131	410		
05:45		141	363	416	1571
06:00		110	310		
06:15		136	237		
06:30		131	190		
06:45		201	169	578	906
07:00		173	155		
07:15		185	122		
07:30		175	125		
07:45		183	91	716	493
08:00		148	106		
08:15		171	97		
08:30		208	84		
08:45		162	73	689	360
09:00		138	80		
09:15		248	70		
09:30		195	54		
09:45		195	57	776	261
10:00		165	69		
10:15		162	59		
10:30		164	42		
10:45		178	38	669	208
11:00		184	50		
11:15		171	37		
11:30		189	26		
11:45		176	27	720	140
Total		5014	7908		
Percent		38.8%	61.2%		
Grand Total		5014	7908		
Percent		38.8%	61.2%		

ADT

ADT 12,922

AADT 12,922

APPENDIX D
SIGNAL TIMING DATA

Access Data

Date:
10/14/2014

Time:
10:36

Intersection Name: US 290 at FM 529 (Const)

Source: Database

		Level 1	Level 2
Security Code:	9999		
	Baud Rate	Data Bits	Parity
Printer Port 2	0-1200	0-Eight	0
Com Port 2	5-19200		
Com Port 3	4-9600		

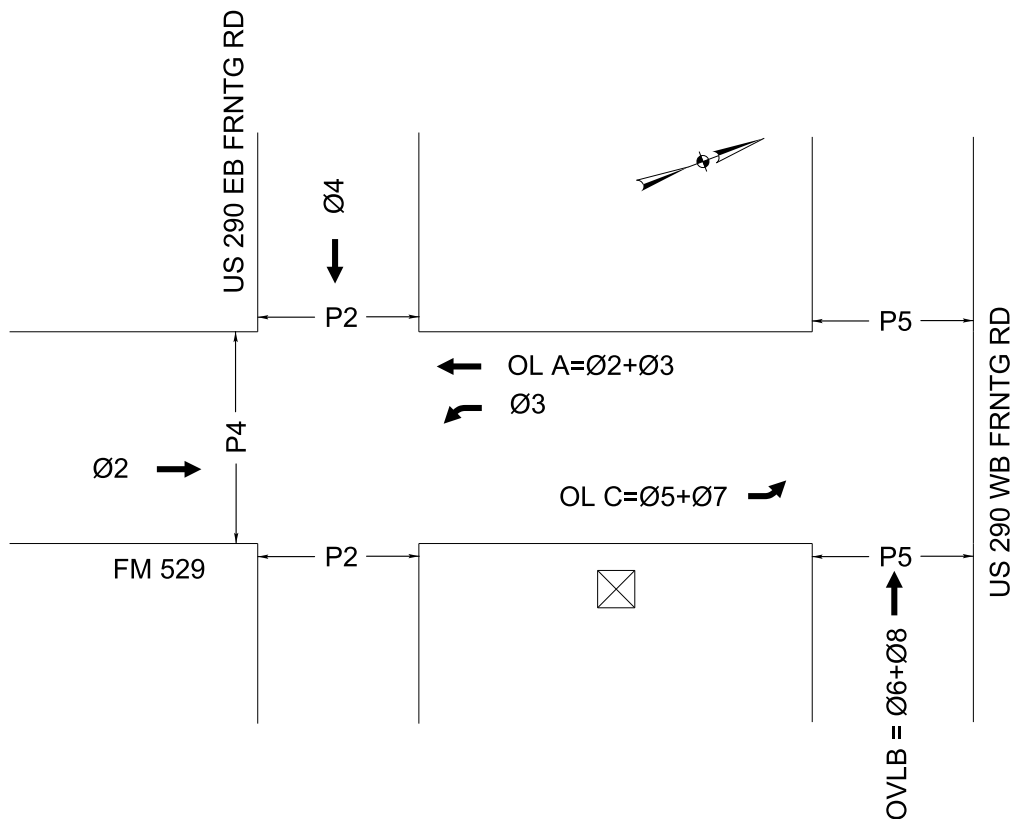

Phase Vehicle Timing Data

Date: 10/14/2014

Time: 10:36:28AM

Intersection Name: US 290 at FM 529 (Const)

Source: Database

PHASES	1	2	3	4	5	6	7	8
Minimum Green	0	10	5	10	5	1	3	10
Passage	0.0	2.0	2.0	2.0	2.0	2.0	2.0	2.0
Maximum 1	0	45	60	60	35	7	50	70
Maximum 2	0	55	60	60	40	7	50	70
Yellow Change	3.0	4.3	4.3	4.3	4.3	4.3	4.3	4.3
Red Clearance	0.0	1.6	1.6	2.9	1.2	2.9	1.2	2.9

PHASES	9	10	11	12	13	14	15	16
Minimum Green	0	0	0	0	0	0	0	0
Passage	0.0	0.0	0.0	0.0	0.0	0.0	0.0	0.0
Maximum 1	0	0	0	0	0	0	0	0
Maximum 2	0	0	0	0	0	0	0	0
Yellow Change	3.0	3.0	3.0	3.0	3.0	3.0	3.0	3.0
Red Clearance	0.0	0.0	0.0	0.0	0.0	0.0	0.0	0.0

Phase Pedestrian Timing Data

Date: 10/14/2014

Time: 10:36:28AM

Intersection Name: US 290 at FM 529 (Const)

Source: Database

PHASES	1	2	3	4	5	6	7	8
Walk	0	5	0	5	5	0	0	0
Pedestrian Clear	0	20	0	20	15	0	0	0
Flashing Walk	0	0	0	0	0	0	0	0
Eextended Ped Cear	0	0	0	0	0	0	0	0
Act Rest in Walk	0	0	0	0	0	0	0	0
PHASES	9	10	11	12	13	14	15	16
Walk	0	0	0	0	0	0	0	0
Pedestrian Clear	0	0	0	0	0	0	0	0
Flashing Walk	0	0	0	0	0	0	0	0
Eextended Ped Cear	0	0	0	0	0	0	0	0
Act Rest in Walk	0	0	0	0	0	0	0	0

Phase General Control Data

Date: 10/14/2014

Time: 10:36:28AM

Intersection Name: US 290 at FM 529 (Const)

Source: Database

PHASES	1	2	3	4	5	6
Initial	0-None	1-Inactive	3-Yellow	1-Inactive	1-Inactive	1-Inactive
Non-Actuated Respons	0-none	0-none	0-none	0-none	0-none	0-none
Vehicle Recall	0-None	3-Max	3-Max	3-Max	3-Max	3-Max
Ped Recall	0-None	0-None	0-None	0-None	0-None	0-None
Recall DDelay	0	0	0	0	0	0

PHASES	7	8	9	10	11	12
Initial	1-Inactive	3-Yellow	0-None	0-None	0-None	0-None
Non-Actuated Respons	0-none	0-none	0-none	0-none	0-none	0-none
Vehicle Recall	3-Max	3-Max	0-None	0-None	0-None	0-None
Ped Recall	0-None	0-None	0-None	0-None	0-None	0-None
Recall DDelay	0	0	0	0	0	0

PHASES	13	14	15	16
Initial	0-None	0-None	0-None	0-None
Non-Actuated Respons	0-none	0-none	0-none	0-none
Vehicle Recall	0-None	0-None	0-None	0-None
Ped Recall	0-None	0-None	0-None	0-None
Recall DDelay	0	0	0	0

Phase Miscellanenous Data

Date: 10/14/2014

Time: 10:36:28AM

Intersection Name: US 290 at FM 529 (Const)

Source: Database

PHASES	1	2	3	4	5	6	7	8
Non-Locking Memory	1	0	1	1	1	0	1	1
Dual Entry	0	1	0	1	0	1	0	1
Last Car Passage	0	0	0	0	0	0	0	0
Conditional Service	0	0	0	0	0	0	0	0
No Simultaneous Gap Out	0	0	0	0	0	0	0	0

PHASES	9	10	11	12	13	14	15	16
Non-Locking Memory	0	0	0	0	0	0	0	0
Dual Entry	0	0	0	0	0	0	0	0
Last Car Passage	0	0	0	0	0	0	0	0
Conditional Service	0	0	0	0	0	0	0	0
No Simultaneous Gap Out	0	0	0	0	0	0	0	0

Phase Vehicle Detector Data

Date: 10/14/2014

Time: 10:36:28AM

Intersection Name: US 290 at FM 529 (Const)

Source: Database

DETECTOR	1	2	3	4	5	6	7	8
Assigned Phase	1	2	3	4	5	6	7	8
Operation Mode	0-Veh	0-Veh	0-Veh	0-Veh	0-Veh	0-Veh	0-Veh	0-Veh
Switch PHase	0	0	0	0	0	0	0	0
Extend	0.0	0.0	0.0	0.0	0.0	0.0	0.0	0.0
Delay	0	0	0	0	0	0	0	0

DETECTOR	9	10	11	12	13	14	15	16
Assigned Phase	0	0	0	0	0	0	0	0
Operation Mode	0-Veh	0-Veh	0-Veh	0-Veh	0-Veh	0-Veh	0-Veh	0-Veh
Switch PHase	0	0	0	0	0	0	0	0
Extend	0.0	0.0	0.0	0.0	0	0.0	0.0	0.0
Delay	0	0	0	0	0	0	0	0

Phase Pestrrian Detector Data

Date: 10/14/2014

Time: 10:36:28AM

Intersection Name: US 290 at FM 529 (Const)

Source: Database

DETECTOR	1	2	3	4	5	6	7	8
Assigned Phase	1	2	3	4	5	6	7	8
Operation Mode	1-Ped	1-Ped	1-Ped	1-Ped	1-Ped	1-Ped	1-Ped	1-Ped
Switch PHase	0	0	0	0	0	0	0	0
Extend	0.0	0.0	0.0	0.0	0.0	0.0	0.0	0.0
Delay	0	0	0	0	0	0	0	0

Unit General Control Data

Date: 10/14/2014

Time: 10:36:28AM

Intersection Name: US 290 at FM 529 (Const)

Source: Database

Startup Time	5	<hr/>				
		RING	1	2	3	4
Startup State	1-All Red	Input Response	Ring 1	Ring 2	None	None
Red Revert	4.0	Output Selection	Ring 1	Ring 2	None	None
Auto Pedestrian Clear	0	<hr/>				
Stop Time Reset	0	I/O Modes	Input	Output		
Alternate Sequence	1	"ABC" Connector	0	0		
		"D" Connector	0	0		

Unit Remote Flash Data

Intersection Name: US 290 at FM 529 (Const)

Date: 10/14/2014

Source: Database

Time: 10:36:28AM

	Channel											
	1	2	3	4	5	6	7	8	9	10	11	12
FLASH	0-No	0-No	0-No	0-No	0-No	0-No	0-No	0-No	0-No	0-No	0-No	0-No
ALT FLASH	0	0	0	0	0	0	0	0	0	0	0	0

	Channel											
	13	14	15	16	17	18	19	20	21	22	23	24
FLASH	0-No	0-No	0-No	0-No	0-No	0-No	0-No	0-No	0-No	0-No	0-No	0-No
ALT FLASH	0	0	0	0	0	0	0	0	0	0	0	0

TEST A = Flash 0

	1	2	3	4	5	6	7	8	9	10	11	12	13	14	15	16
Flash Entry	0	0	0	0	0	0	0	0	0	0	0	0	0	0	0	0
Flash Exit	0	0	0	0	0	0	0	0	0	0	0	0	0	0	0	0

Unit Overlap Data

Intersection Name: US 290 at FM 529 (Const)

Date: 10/14/2014

Source: Database

Time: 10:36:28AM

<u>PHASE</u>	2	3	5	6	7	8
Overlap A	1	1	0	0	0	0
Overlap B	0	0	0	1	0	1
Overlap C	0	0	1	0	1	0

Codes: 0=NO 1=YES Phase is included in overla

OVERLAP	A	B	C	D	E	F	G	H	I	J	K	L	M	N	O	P
TRL GRN	0	0	0	0	0	0	0	0	0	0	0	0	0	0	0	0
YEL/10	45	45	45	40	40	40	40	40	40	40	40	40	40	40	40	40
RED/10	15	15	15	20	20	20	20	20	20	20	20	20	20	20	20	20
-GRN/YEL	0	0	0	0	0	0	0	0	0	0	0	0	0	0	0	0
+GRN	0	0	0	0	0	0	0	0	0	0	0	0	0	0	0	0

Unit Ring Data

Intersection Name US 290 at FM 529 (Const) **Date** 10/14/2014
Source Database **Time** 10:26:49AM

Concurrent Phases

Phase	Ring	Next	1	2	3	4	5	6	7	8	9	1	1	12	1	1	1	16
1	1	2	1	0	0	0	1	1	0	0	0	0	0	0	0	0	0	0
2	1	3	0	1	0	0	1	1	0	0	0	0	0	0	0	0	0	0
3	1	4	0	0	1	0	0	0	1	1	0	0	0	0	0	0	0	0
4	1	1	0	0	0	1	0	0	1	1	0	0	0	0	0	0	0	0
5	2	6	1	1	0	0	1	0	0	0	0	0	0	0	0	0	0	0
6	2	7	1	1	0	0	0	1	0	0	0	0	0	0	0	0	0	0
7	2	8	0	0	1	1	0	0	1	0	0	0	0	0	0	0	0	0
8	2	5	0	0	1	1	0	0	0	1	0	0	0	0	0	0	0	0
9	0	0	0	0	0	0	0	0	0	0	1	0	0	0	0	0	0	0
10	0	0	0	0	0	0	0	0	0	0	0	1	0	0	0	0	0	0
11	0	0	0	0	0	0	0	0	0	0	0	0	1	0	0	0	0	0
12	0	0	0	0	0	0	0	0	0	0	0	0	0	1	0	0	0	0
13	0	0	0	0	0	0	0	0	0	0	0	0	0	0	1	0	0	0
14	0	0	0	0	0	0	0	0	0	0	0	0	0	0	0	1	0	0
15	0	0	0	0	0	0	0	0	0	0	0	0	0	0	0	0	1	0
16	0	0	0	0	0	0	0	0	0	0	0	0	0	0	0	0	0	1

Unit Alt Sequence Data

Intersection Name: US 290 at FM 529 (Const)

Date: 10/14/2014

Source: Database

Time: 10:36:28AM

Alternate Sequence	Pair 1		Pair 2		Pair 3		Pair 4	
	1/1	1/2	2/1	2/2	3/1	3/2	4/1	4/2
1	3	4	5	6	0	0	0	0
2	0	0	0	0	0	0	0	0
3	0	0	0	0	0	0	0	0
4	0	0	0	0	0	0	0	0
5	0	0	0	0	0	0	0	0
6	0	0	0	0	0	0	0	0
7	0	0	0	0	0	0	0	0
8	0	0	0	0	0	0	0	0
9	0	0	0	0	0	0	0	0
10	0	0	0	0	0	0	0	0
11	0	0	0	0	0	0	0	0
12	0	0	0	0	0	0	0	0
13	0	0	0	0	0	0	0	0
14	0	0	0	0	0	0	0	0
15	0	0	0	0	0	0	0	0

Unit Channel Output Data

Intersection Name	US 290 at FM 529 (Const)	Date	10/14/2014
Source	Database	Time	10:26:49AM

Channel	Control	Hardware Pin
1-Phase 1 Vehicle	1-Veh Phase 1	1-Phase 1 RYG
2-Phase 2 Vehicle	2-Veh Phase 2	2-Phase 2 RYG
3-Phase 3 Vehicle	3-Veh Phase 3	3-Phase 3 RYG
4-Phase 4 Vehicle	4-Veh Phase 4	4-Phase4 RYG
5-Phase 5 Vehicle	5-Veh Phase 5	5-Phase 5 RYG
6-Phase 6 Vehicle	6-Veh Phase 6	6-Phase 6 RYG
7-Phase 7 Vehicle	7-Veh Phase 7	7-Phase 7 RYG
8-Phase 8 Vehicle	8-Veh Phase 8	8-Phase 8 RYG
9-Phase 9 Vehicle	18-Ped Phase 2	10-Phase 2 DPW
10-Phase 10 Vehicle	20-Ped Phase 4	12-Phase 4 DPW
11-Phase 11 Vehicle	21-Ped Phase 5	14-Phase 6 DPW
12-Phase 12 Vehicle	0-None	16-Phase 8 DPW

Unit Channel Output Data

Intersection Name	US 290 at FM 529 (Const)	Date	10/14/2014
Source	Database	Time	10:26:49AM

Channel	Control	Hardware Pin
13-Overlap A Vehicle	33-Overlap A	17-Overlap A RYG
14-Overlap B Vehicle	34-Overlap B	18-Overlap B RYG
15-Overlap C Vehicle	35-Overlap C	19-Overlap C RYG
16-Overlap D Vehicle	36-Overlap D	20-Overlap D RYG
17-Phase 1 Ped	17-Ped Phase 1	9-Phase 1 DPW
18-Phase 3 Ped	19-Ped Phase 3	11-Phase 3 DPW
19-Phase 5 Ped	0-None	13-Phase 5 DPW
20-Phase 7 Ped	23-Ped Phase 7	15-Phase 7 DPW
21-Overlap E Vehicle	0-None	0-None
22-Overlap F Vehicle	0-None	0-None
23-Overlap G Vehicle	0-None	0-None
24-Overlap H Vehicle	0-None	0-None

Coordination Mode Data

Date 6/29/2017 Time 11:26

Intersection Name	US 290 at FM 529 (Const)
Source	Database
Operation Mode	1-Auto
Mode (Normal)	0-Perm
Maximum	2-Max II
Correction	2-Short Way
Offset Mode	0-Beg Green
Force Mode	0-Plan
Max Dwell Time	0
Yield Period	0
Manual Controls: Dial	1
Split	1
Offset	1

Coordination Timing Plan Data - Dial 1 Split 2

Date 6/29/201 Time 11:26

Intersection Name US 290 at FM 529 (Const)

Source Database

Cycle Length 90

Ring Sum Times 90 90 0 0

Phase	Phase 1	Phase 2	Phase 3	Phase 4	Phase 5	Phase 6	Phase 7	Phase 8
Time	0	39	17	34	26	13	22	29
Mode	0-Actuated	0-Actuated	1-Coord Ph	0-Actuated	0-Actuated	0-Actuated	0-Actuated	1-Coord Ph
Ph Min Veh Serv	0	16	11	18	11	13	11	18
Ph Min Ped Serv								

Phase	Phase 9	Phase 10	Phase 11	Phase 12	Phase 13	Phase 14	Phase 15	Phase 16
Time	0	0	0	0	0	0	0	0
Mode	0-Actuated	0-Actuated	0-Actuated	0-Actuated	0-Actuated	0-Actuated	0-Actuated	0-Actuated
Ph Min Veh Serv	0	0	0	0	0	0	0	0
Ph Min Ped Serv								

Offset	Offset 1	Offset 2	Offset 3
Time	40	0	0
Mode	0-Normal	0-Normal	0-Normal
Alternate	1	0	0
Sequence	0	0	0
Ring 2 Lag Time	0	0	0
Ring 3 Lag Time	0	0	0
Ring 4 Lag Time			

Coordination Timing Plan Data - Dial 2 Split 1

Date 6/29/201 Time 11:26

Intersection Name US 290 at FM 529 (Const)

Source Database

Cycle Length 140

Ring Sum Times 140 140 0 0

Phase	Phase 1	Phase 2	Phase 3	Phase 4	Phase 5	Phase 6	Phase 7	Phase 8
Time	0	55	18	67	42	13	56	29
Mode	0-Actuated	0-Actuated	1-Coord Ph	0-Actuated	0-Actuated	0-Actuated	0-Actuated	1-Coord Ph
Ph Min Veh Serv	0	16	11	18	11	13	11	18
Ph Min Ped Serv								

Phase	Phase 9	Phase 10	Phase 11	Phase 12	Phase 13	Phase 14	Phase 15	Phase 16
Time	0	0	0	0	0	0	0	0
Mode	0-Actuated	0-Actuated	0-Actuated	0-Actuated	0-Actuated	0-Actuated	0-Actuated	0-Actuated
Ph Min Veh Serv	0	0	0	0	0	0	0	0
Ph Min Ped Serv								

Offset	Offset 1	Offset 2	Offset 3
Time	102	122	0
Mode	0-Normal	0-Normal	0-Normal
Alternate	1	1	0
Sequence	0	0	0
Ring 2 Lag Time	0	0	0
Ring 3 Lag Time	0	0	0
Ring 4 Lag Time			

Coordination Timing Plan Data - Dial 3 Split 1

Date 6/29/201 Time 11:26

Intersection Name US 290 at FM 529 (Const)

Source Database

Cycle Length 135

Ring Sum Times 135 135 0 0

Phase	Phase 1	Phase 2	Phase 3	Phase 4	Phase 5	Phase 6	Phase 7	Phase 8
Time	0	34	72	29	21	13	17	84
Mode	0-Actuated	0-Actuated	1-Coord Ph	0-Actuated	0-Actuated	0-Actuated	0-Actuated	1-Coord
Ph Min Veh Serv	0	16	11	18	11	13	11	Ph
Ph Min Ped Serv								18

Phase	Phase 9	Phase 10	Phase 11	Phase 12	Phase 13	Phase 14	Phase 15	Phase 16
Time	0	0	0	0	0	0	0	0
Mode	0-Actuated	0-Actuated	0-Actuated	0-Actuated	0-Actuated	0-Actuated	0-Actuated	0-Actuated
Ph Min Veh Serv	0	0	0	0	0	0	0	0
Ph Min Ped Serv								

Offset	Offset 1	Offset 2	Offset 3
Time	13	0	0
Mode	0-Normal	0-Normal	0-Normal
Alternate Sequence	1	0	0
Ring 2 Lag Time	0	0	0
Ring 3 Lag Time	0	0	0
Ring 4 Lag Time	0	0	0

Coordination Timing Plan Data - Dial 3 Split 2

Date 6/29/201 Time 11:26

Intersection Name US 290 at FM 529 (Const)

Source Database

Cycle Length 135

Ring Sum Times 135 135 0 0

Phase	Phase 1	Phase 2	Phase 3	Phase 4	Phase 5	Phase 6	Phase 7	Phase 8
Time	0	29	77	29	16	13	17	89
Mode	0-Actuated	0-Actuated	1-Coord Ph	0-Actuated	0-Actuated	0-Actuated	0-Actuated	1-Coord Ph
Ph Min Veh Serv	0	16	11	18	11	13	11	18
Ph Min Ped Serv								

Phase	Phase 9	Phase 10	Phase 11	Phase 12	Phase 13	Phase 14	Phase 15	Phase 16
Time	0	0	0	0	0	0	0	0
Mode	0-Actuated	0-Actuated	0-Actuated	0-Actuated	0-Actuated	0-Actuated	0-Actuated	0-Actuated
Ph Min Veh Serv	0	0	0	0	0	0	0	0
Ph Min Ped Serv								

Offset	Offset 1	Offset 2	Offset 3
Time	13	0	0
Mode	0-Normal	0-Normal	0-Normal
Alternate Sequence	1	0	0
Ring 2 Lag Time	0	0	0
Ring 3 Lag Time	0	0	0
Ring 4 Lag Time	0	0	0

Coordination Timing Plan Data - Dial 4 Split 1

Date 6/29/201 Time 11:26

Intersection Name US 290 at FM 529 (Const)

Source Database

Cycle Length 80

Ring Sum Times 80 80 0 0

Phase	Phase 1	Phase 2	Phase 3	Phase 4	Phase 5	Phase 6	Phase 7	Phase 8
Time	0	34	17	29	21	13	18	28
Mode	0-Actuated	0-Actuated	1-Coord Ph	0-Actuated	0-Actuated	0-Actuated	0-Actuated	1-Coord Ph
Ph Min Veh Serv	0	16	11	18	11	13	11	18
Ph Min Ped Serv								

Phase	Phase 9	Phase 10	Phase 11	Phase 12	Phase 13	Phase 14	Phase 15	Phase 16
Time	0	0	0	0	0	0	0	0
Mode	0-Actuated	0-Actuated	0-Actuated	0-Actuated	0-Actuated	0-Actuated	0-Actuated	0-Actuated
Ph Min Veh Serv	0	0	0	0	0	0	0	0
Ph Min Ped Serv								

Offset	Offset 1	Offset 2	Offset 3
Time	43	0	0
Mode	0-Normal	0-Normal	0-Normal
Alternate Sequence	1	0	0
Ring 2 Lag Time	0	0	0
Ring 3 Lag Time	0	0	0
Ring 4 Lag Time	0	0	0

Coordination Timing Plan Data - Dial 4 Split 2

Date 6/29/201 Time 11:26

Intersection Name US 290 at FM 529 (Const)

Source Database

Cycle Length 90

Ring Sum Times 90 90 0 0

Phase	Phase 1	Phase 2	Phase 3	Phase 4	Phase 5	Phase 6	Phase 7	Phase 8
Time	0	38	16	36	25	13	25	27
Mode	0-Actuated	0-Actuated	1-Coord Ph	0-Actuated	0-Actuated	0-Actuated	0-Actuated	1-Coord Ph
Ph Min Veh Serv	0	16	11	18	11	13	11	18
Ph Min Ped Serv								

Phase	Phase 9	Phase 10	Phase 11	Phase 12	Phase 13	Phase 14	Phase 15	Phase 16
Time	0	0	0	0	0	0	0	0
Mode	0-Actuated	0-Actuated	0-Actuated	0-Actuated	0-Actuated	0-Actuated	0-Actuated	0-Actuated
Ph Min Veh Serv	0	0	0	0	0	0	0	0
Ph Min Ped Serv								

Offset	Offset 1	Offset 2	Offset 3
Time	58	0	0
Mode	0-Normal	0-Normal	0-Normal
Alternate Sequence	1	0	0
Ring 2 Lag Time	0	0	0
Ring 3 Lag Time	0	0	0
Ring 4 Lag Time	0	0	0

Local TBC DST and Equate Data

Date: 10/14/2014

Time: 10:36:28AM

Intersection Name: US 290 at FM 529 (Const)

Source: Database

	Month	Week
DST Begin	3	2
DST End	11	1
	Hour	Minute
Cycle Zero Reference time	24	0

	Equates						
Source	1	2	3	4	5	6	7
1	7	0	0	0	0	0	0
2	3	4	5	6	0	0	0

Local TBC Traffic Data

Intersection US 290 at FM 529 (Const)

Date 6/29/2017

Source Database



















Time 11:27:31

Day	HH	MM	Pattern	Phase Functions															
				1	2	3	4	5	6	7	8	9	10	11	12	13	14	15	16
1	1	0	1	4/1/1	0	0	0	0	0	0	0	0	0	0	0	0	0	0	0
2	1	9	0	4/2/1	0	0	0	0	0	0	0	0	0	0	0	0	0	0	0
3	1	19	30	4/1/1	0	0	0	0	0	0	0	0	0	0	0	0	0	0	0
4	1	22	0	4/1/1	0	0	0	0	0	0	0	0	0	0	0	0	0	0	0
5	2	0	1	4/1/1	0	0	0	0	0	0	0	0	0	0	0	0	0	0	0
6	2	6	0	2/1/1	0	0	0	0	0	0	0	0	0	0	0	0	0	0	0
7	2	7	0	2/1/2	0	0	0	0	0	0	0	0	0	0	0	0	0	0	0
8	2	8	30	2/1/1	0	0	0	0	0	0	0	0	0	0	0	0	0	0	0
9	2	9	0	1/2/1	0	0	0	0	0	0	0	0	0	0	0	0	0	0	0
10	2	15	30	3/1/1	0	0	0	0	0	0	0	0	0	0	0	0	0	0	0
11	2	16	45	3/2/1	0	0	0	0	0	0	0	0	0	0	0	0	0	0	0
12	2	19	30	4/1/1	0	0	0	0	0	0	0	0	0	0	0	0	0	0	0
13	2	22	0	4/1/1	0	0	0	0	0	0	0	0	0	0	0	0	0	0	0
14	0	0	0		0	0	0	0	0	0	0	0	0	0	0	0	0	0	0
15	0	0	0		0	0	0	0	0	0	0	0	0	0	0	0	0	0	0
16	0	0	0		0	0	0	0	0	0	0	0	0	0	0	0	0	0	0
17	0	0	0		0	0	0	0	0	0	0	0	0	0	0	0	0	0	0
18	0	0	0		0	0	0	0	0	0	0	0	0	0	0	0	0	0	0
19	0	0	0		0	0	0	0	0	0	0	0	0	0	0	0	0	0	0
20	0	0	0		0	0	0	0	0	0	0	0	0	0	0	0	0	0	0
21	0	0	0		0	0	0	0	0	0	0	0	0	0	0	0	0	0	0
22	0	0	0		0	0	0	0	0	0	0	0	0	0	0	0	0	0	0
23	0	0	0		0	0	0	0	0	0	0	0	0	0	0	0	0	0	0
24	0	0	0		0	0	0	0	0	0	0	0	0	0	0	0	0	0	0

TRAFFIC SIGNAL POLE DESCRIPTIONS			
POLE #	POLE TYPE	MAST ARM LENGTHS	ATTACHMENTS
POLE 1	EXIST	EXIST	SMA, LUM, PB1, PB2, W1, W2, S1
POLE 2	EXIST	EXIST	SMA, PB3/4, W3, W4, S2
POLE 3	10'		PB5, W5
POLE 4	10'		PB6, W6
POLE 5	10'		PB7, W7
POLE 6	30'	65'	SMA, LUM, S3, S8
POLE 7	10'		PB8, W8

- NOTES:
1. LOCATION OF UNDERGROUND AND ABOVE GROUND INSTALLATIONS IS APPROXIMATE. IT IS THE CONTRACTOR'S RESPONSIBILITY TO VERIFY ALL UTILITY LOCATIONS PRIOR TO ANY CONSTRUCTION. SEE "TRAFFIC SIGNAL UTILITY LAYOUT" SHEET FOR MORE DETAILS.
 2. ABANDON ALL CONDUIT, CABLE AND GROUND BOXES THAT WILL NOT BE REUSED AS PART OF THE PROPOSED SIGNAL INSTALLATION AT THIS LOCATION.
 3. SEE "LEGEND FOR PLAN LAYOUT" SHEET FOR ALL PROPOSED OVERHEAD SIGN DESIGNS, ELECTRICAL SCHEDULE AND LOOP DETECTOR DESIGNATION TABLE.
 4. PEDESTRIAN SIGNALS AND PUSH BUTTONS ARE TO BE WIRED IN SERIES.
 5.  EXISTING MAST ARM AND POLE

LEGEND

-  CONTROLLER W/CABINET & BBU
-  CONDUIT
-  BORE CONDUIT
-  BRIDGE MOUNTED CONDUIT
-  GROUND BOX TYPE D WITH APRON
-  GROUND BOX TYPE 2 WITH APRON
-  HORIZONTAL TRAFFIC SIGNAL HEAD
-  VERTICAL TRAFFIC SIGNAL HEAD
-  PEDESTRIAN SIGNAL HEAD
-  VIVDS DETECTOR
-  MAST ARM AND POLE
-  PEDESTAL POLE
-  LOOP DETECTOR
-  ELECTRICAL SERVICE
-  LUMINAIRE WITH 10' ARM
-  SMALL SIGN
-  PEDESTRIAN PUSH BUTTON
-  PROPOSED VIVDS DETECTION ZONE
-  PROPOSED RUN NUMBER

STATE OF TEXAS
 JAMES H. HILLS
 91908
 LICENSED PROFESSIONAL ENGINEER
 Dale H. Hilliard, P.E.
 2/22/2013
 TXDOT

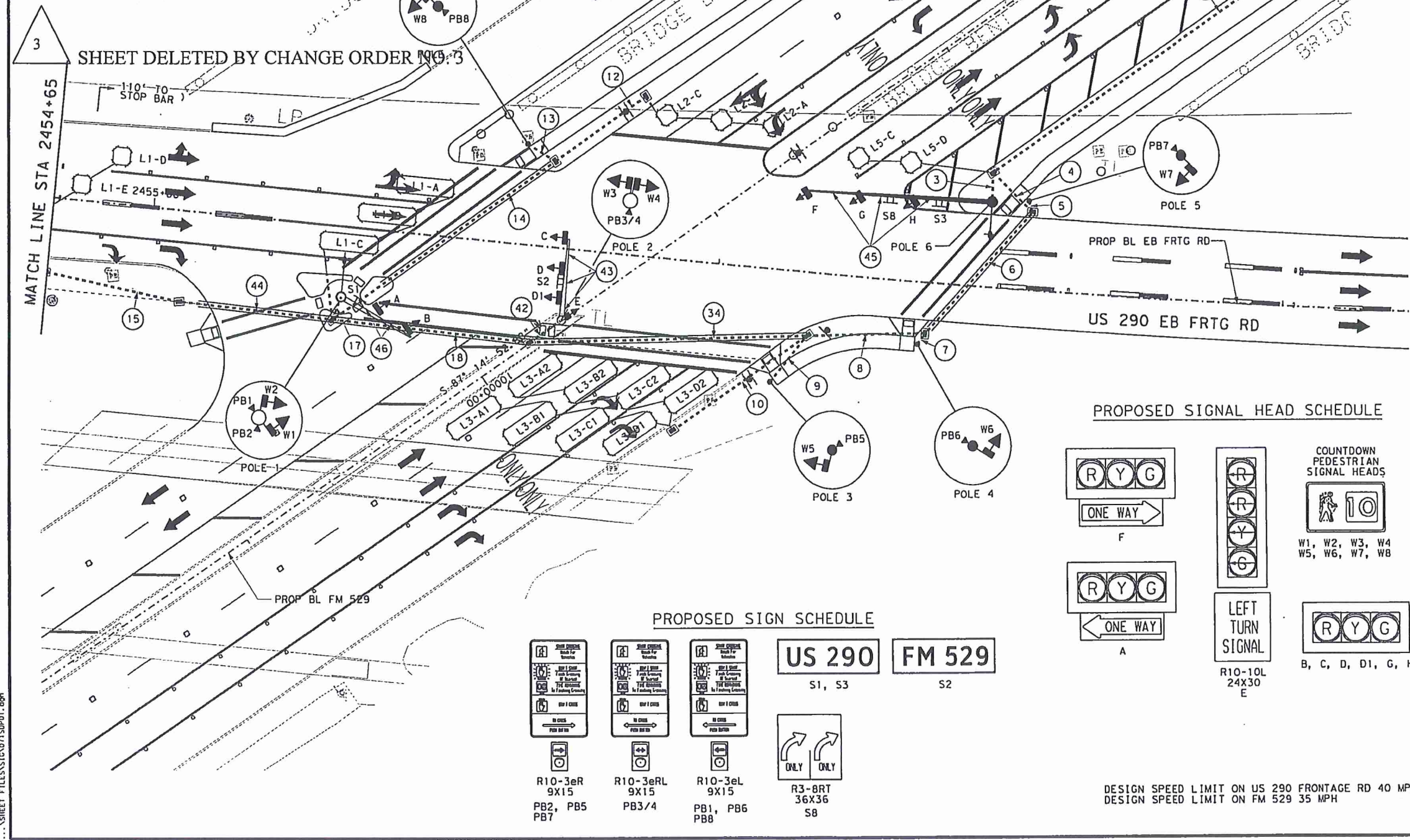

SHEET DELETED BY CHANGE ORDER NO. 3

PROPOSED SIGNAL HEAD SCHEDULE

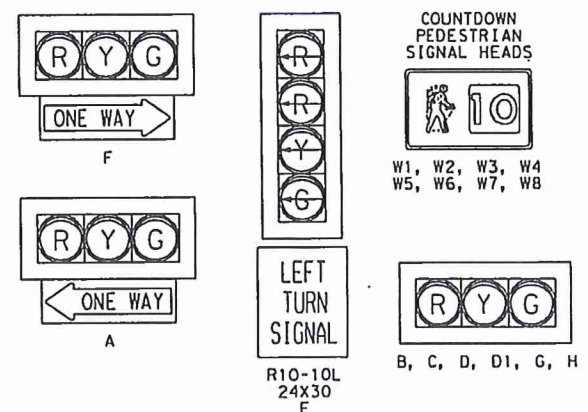

PROPOSED SIGN SCHEDULE

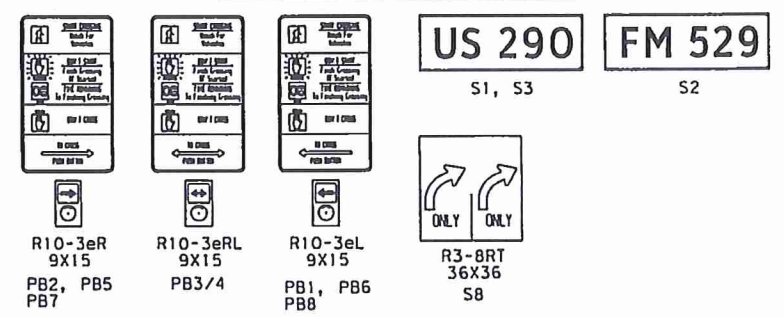

STATE OF TEXAS
 DALE H. HILLIARD
 70892
 LICENSED PROFESSIONAL ENGINEER
 THE SEAL APPEARING ON THIS DOCUMENT WAS AUTHORIZED BY DALE H. HILLIARD, P.E. 70892 ON 5/21/2012
 Dale H. Hilliard



REV. NO.	DATE	DESCRIPTION	BY
EXCELSIS, INC. CONSULTING ENGINEERS 2825 WILCREST DR., SUITE 100 HOUSTON, TEXAS 77042 <small>TYPE NO. F-731</small>			
 2012			
US 290 PROPOSED TRAFFIC SIGNAL LAYOUT FM 529			
SHEET 1 OF 3			
DSH:	FED. PROJ. NO.	STATE	PROJECT NO.
ECI:	6	TEXAS	US 290
DRN:	STATE DISTRICT	COUNTY	CONTROL SECTION NO.
CEL:	HOU	HARRIS	0050 09 071, ETC
			JOB NO. SHEET NO.
			2043

DESIGN SPEED LIMIT ON US 290 FRONTAGE RD 40 MPH
 DESIGN SPEED LIMIT ON FM 529 35 MPH

5/21/2012 10:11:09 AM
 ...SHEET FILES\SID\07150P01.dgn

TRAFFIC SIGNAL POLE DESCRIPTIONS			
POLE #	POLE TYPE	MAST ARM LENGTHS	ATTACHMENTS
POLE 1	EXIST	EXIST	SMA, LUM, PB1, PB2, W1, W2, S1
POLE 2	EXIST	EXIST	SMA, PB3/4, W3, W4, S2
POLE 3	10'		PB5, W5
POLE 4	10'		PB6, W6
POLE 5	10'		PB7, W7
POLE 6	30'	65'	SMA, LUM, S3, S8
POLE 7	10'		PBB, W8

- NOTES:
1. LOCATION OF UNDERGROUND AND ABOVE GROUND INSTALLATIONS IS APPROXIMATE. IT IS THE CONTRACTOR'S RESPONSIBILITY TO VERIFY ALL UTILITY LOCATIONS PRIOR TO ANY CONSTRUCTION. SEE "TRAFFIC SIGNAL UTILITY LAYOUT" SHEET FOR MORE DETAILS.
 2. ABANDON ALL CONDUIT, CABLE AND GROUND BOXES THAT WILL NOT BE REUSED AS PART OF THE PROPOSED SIGNAL INSTALLATION AT THIS LOCATION.
 3. SEE "LEGEND FOR PLAN LAYOUT" SHEET FOR ALL PROPOSED OVERHEAD SIGN DESIGNS, ELECTRICAL SCHEDULE AND LOOP DETECTOR DESIGNATION TABLE.
 4. PEDESTRIAN SIGNALS AND PUSH BUTTONS ARE TO BE WIRED IN SERIES.
 5. EXISTING MAST ARM AND POLE

LEGEND

- CONTROLLER W/CABINET & BBU
- CONDUIT
- BORE CONDUIT
- BRIDGE MOUNTED CONDUIT
- GROUND BOX TYPE D WITH APRON
- GROUND BOX TYPE 2 WITH APRON
- HORIZONTAL TRAFFIC SIGNAL HEAD
- VERTICAL TRAFFIC SIGNAL HEAD
- PEDESTRIAN SIGNAL HEAD
- VIVDS DETECTOR
- MAST ARM AND POLE
- PEDESTAL POLE
- LOOP DETECTOR
- ELECTRICAL SERVICE
- LUMINAIRE WITH 10' ARM
- SMALL SIGN
- PEDESTRIAN PUSH BUTTON
- PROPOSED VIVDS DETECTION ZONE
- PROPOSED RUN NUMBER



THE SEAL APPEARING ON THIS DOCUMENT WAS AUTHORIZED BY DALE H. HILLIARD, P.E. 70892 ON 9/17/2012

Dale H. Hilliard

3 SHEET ADDED BY CHANGE ORDER NO. 3

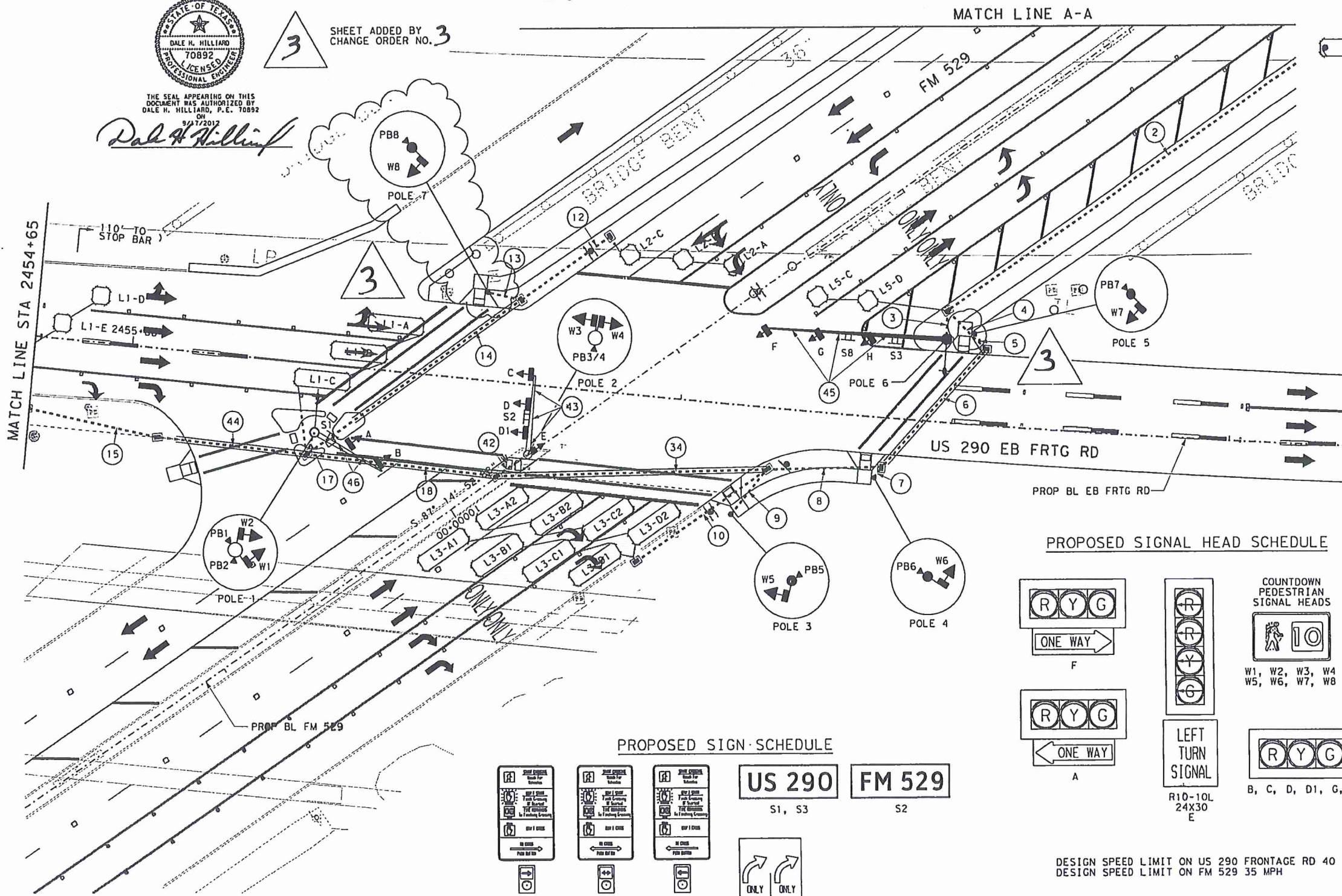

PROPOSED SIGNAL HEAD SCHEDULE

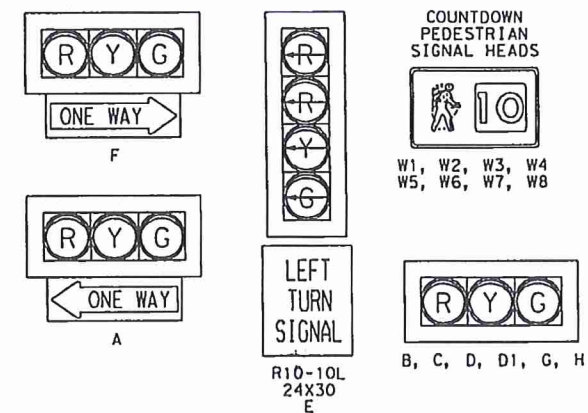

PROPOSED SIGN SCHEDULE

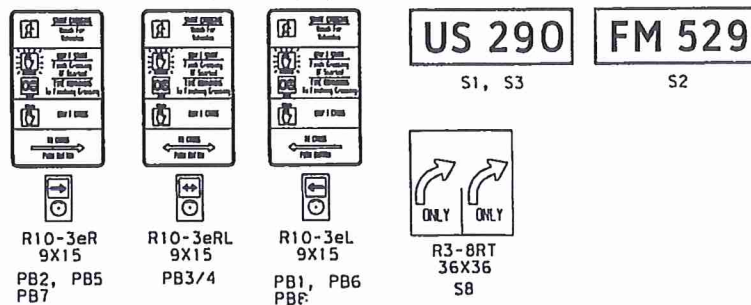

DESIGN SPEED LIMIT ON US 290 FRONTAGE RD 40 MPH
DESIGN SPEED LIMIT ON FM 529 35 MPH



THE SEAL APPEARING ON THIS DOCUMENT WAS AUTHORIZED BY DALE H. HILLIARD, P.E. 70892 ON 9/17/2012

Dale H. Hilliard

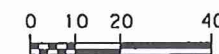

REV. NO.	DATE	DESCRIPTION	B
EXCELSIS, INC. CONSULTING ENGINEERS 2825 WILCREST DR, SUITE 100 HOUSTON, TEXAS 77042 TYPE NO. F-731			
US 290 PROPOSED TRAFFIC SIGNAL LAYOUT FM 529 2043A			
SHEET 1 OF 3			
DSH:	FLV. NO.:	STATE:	PROJECT NO.:
CK:	6	TEXAS	US 290
DR:	STATE DISTRICT:	COUNTY:	CONTROL SECTION:
	HOU	HARRIS	0050 09 071, ETC
			SHEET NO. 2043A

sgrove

9/17/2012 10:15:50 AM
...\\server1\p01\SP01A.dgn

TRAFFIC SIGNAL POLE DESCRIPTIONS			
POLE #	POLE TYPE	MAST ARM LENGTHS	ATTACHMENTS
POLE 8	30'	24'	SMA, LUM, PB9, W9, S5
POLE 9	10'		PB10, W10
POLE 10	10'		PB11, W11
POLE 11	10'		PB12, W12
POLE 12	19'	40'	SMA, S4
POLE 13			METER W/DISCONNECT

NOTES:

1. LOCATION OF UNDERGROUND AND ABOVE GROUND INSTALLATIONS IS APPROXIMATE. IT IS THE CONTRACTOR'S RESPONSIBILITY TO VERIFY ALL UTILITY LOCATIONS PRIOR TO ANY CONSTRUCTION. SEE "TRAFFIC SIGNAL UTILITY LAYOUT" SHEET FOR MORE DETAILS.
2. ABANDON ALL CONDUIT, CABLE AND GROUND BOXES THAT WILL NOT BE REUSED AS PART OF THE PROPOSED SIGNAL INSTALLATION AT THIS LOCATION.
3. SEE "LEGEND FOR PLAN LAYOUT" SHEET FOR ALL PROPOSED OVERHEAD SIGN DESIGNS, ELECTRICAL SCHEDULE AND LOOP DETECTOR DESIGNATION TABLE.
4. PEDESTRIAN SIGNALS AND PUSH BUTTONS ARE TO BE WIRED IN SERIES.

LEGEND

- CONTROLLER W/CABINET & BBU
- CONDUIT
- BORE CONDUIT
- BRIDGE MOUNTED CONDUIT
- GROUND BOX TYPE D WITH APRON
- GROUND BOX TYPE 2 WITH APRON
- HORIZONTAL TRAFFIC SIGNAL HEAD
- VERTICAL TRAFFIC SIGNAL HEAD
- PEDESTRIAN SIGNAL HEAD
- VIVDS DETECTOR
- MAST ARM AND POLE
- PEDESTAL POLE
- LOOP DETECTOR
- ELECTRICAL SERVICE
- LUMINAIRE WITH 10' ARM
- SMALL SIGN
- PEDESTRIAN PUSH BUTTON
- PROPOSED VIVDS DETECTION ZONE
- PROPOSED RUN NUMBER

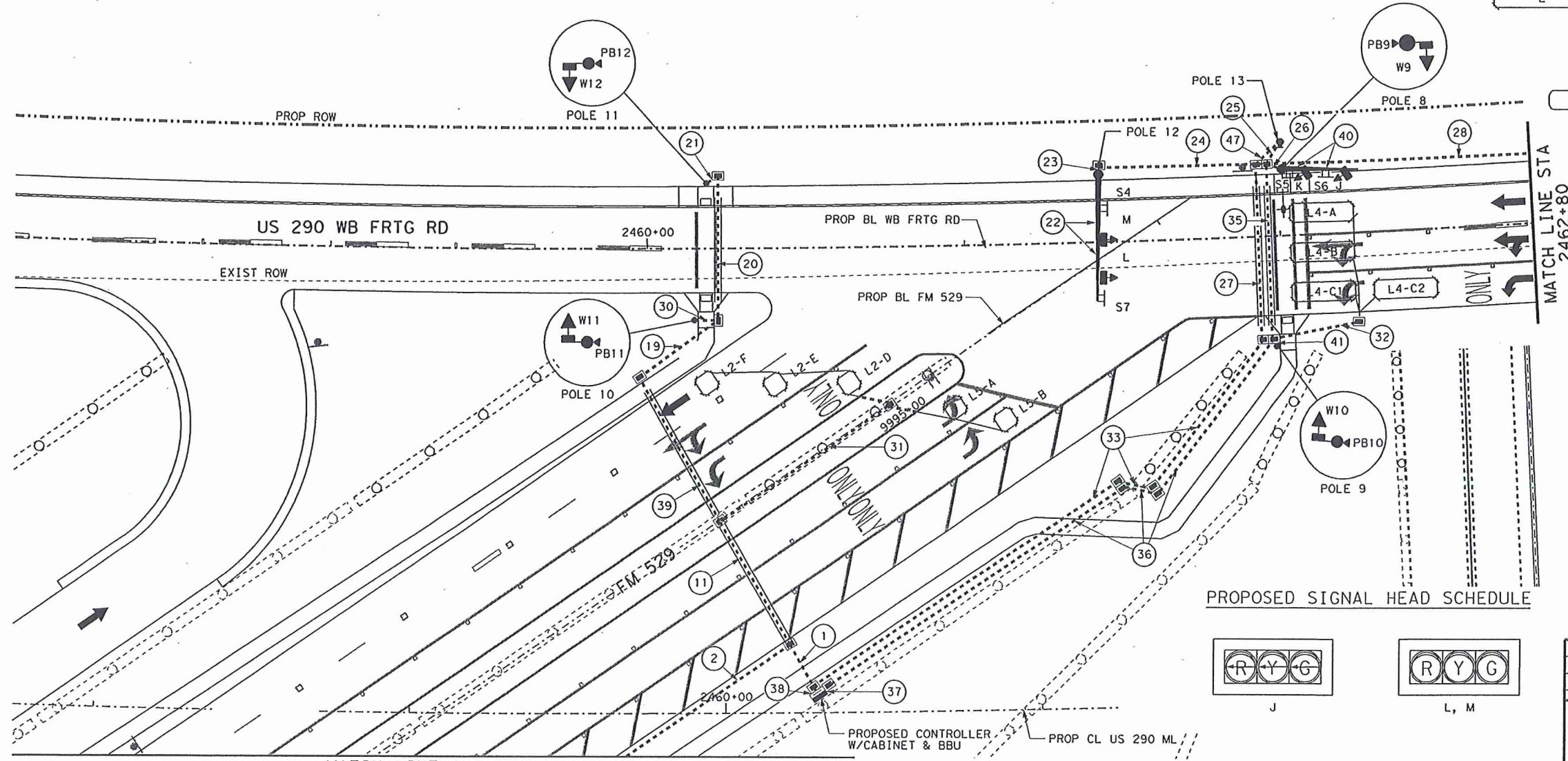

THE SEAL APPEARING ON THIS DOCUMENT WAS AUTHORIZED BY DALE H. HILLIARD, P.E. 70892 ON 5/21/2012

Dale H. Hilliard

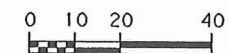

PROPOSED SIGNAL HEAD SCHEDULE

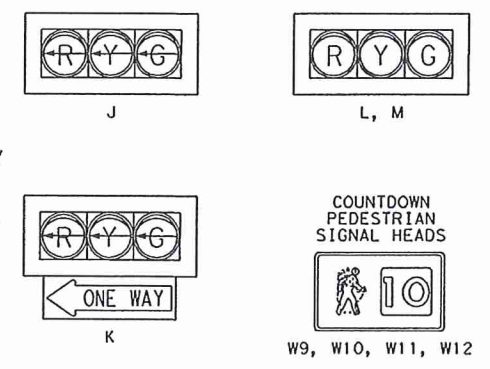

PROPOSED SIGN SCHEDULE

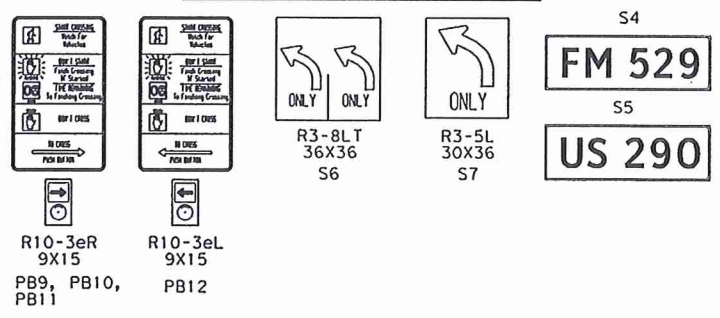

DESIGN SPEED LIMIT ON US 290 FRONTAGE RD 40 MPH
DESIGN SPEED LIMIT ON FM 529 35 MPH

REV. NO.	DATE	DESCRIPTION	BY
EXCELSIS, INC. CONSULTING ENGINEERS 2825 WILCREST DR, SUITE 100 HOUSTON, TEXAS 77042 <small>TBPE NO. F-731</small>			
US 290 PROPOSED TRAFFIC SIGNAL LAYOUT FM 529			
SHEET 2 OF 3			
DS#:	FED. RD. DIV. NO.	STATE	PROJECT NO.
CK#:	6	TEXAS	US 290
DR#:	STATE DISTRICT	COUNTY	CONTROL NO. SECTION NO. JOB NO.
CK#:	HOU	HARRIS	0050 09 071, ETC 2044

5/21/2012 10:11:19 AM
 ...SHEET FILES\515\071SDP02.cpo

NOTES:

1. LOCATION OF UNDERGROUND AND ABOVE GROUND INSTALLATIONS IS APPROXIMATE. IT IS THE CONTRACTOR'S RESPONSIBILITY TO VERIFY ALL UTILITY LOCATIONS PRIOR TO ANY CONSTRUCTION. SEE "TRAFFIC SIGNAL UTILITY LAYOUT" SHEET FOR MORE DETAILS.
2. ABANDON ALL CONDUIT, CABLE AND GROUND BOXES THAT WILL NOT BE REUSED AS PART OF THE PROPOSED SIGNAL INSTALLATION AT THIS LOCATION.
3. SEE "LEGEND FOR PLAN LAYOUT" SHEET FOR LOOP DETECTOR DESIGNATION TABLE.

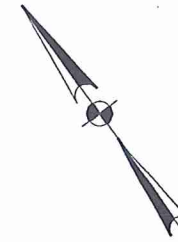

LEGEND

- CONTROLLER W/CABINET & BBU
- CONDUIT
- BORE CONDUIT
- BRIDGE MOUNTED CONDUIT
- GROUND BOX TYPE D WITH APRON
- GROUND BOX TYPE 2 WITH APRON
- HORIZONTAL TRAFFIC SIGNAL HEAD
- VERTICAL TRAFFIC SIGNAL HEAD
- PEDESTRIAN SIGNAL HEAD
- VIVDS DETECTOR
- MAST ARM AND POLE
- PEDESTAL POLE
- LOOP DETECTOR
- ELECTRICAL SERVICE
- LUMINAIRE WITH 10' ARM
- SMALL SIGN
- PEDESTRIAN PUSH BUTTON
- PROPOSED VIVDS DETECTION ZONE
- PROPOSED RUN NUMBER

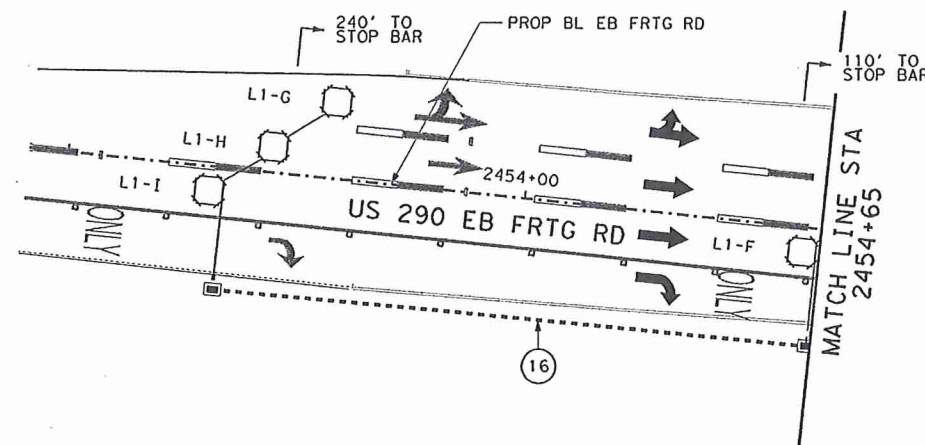
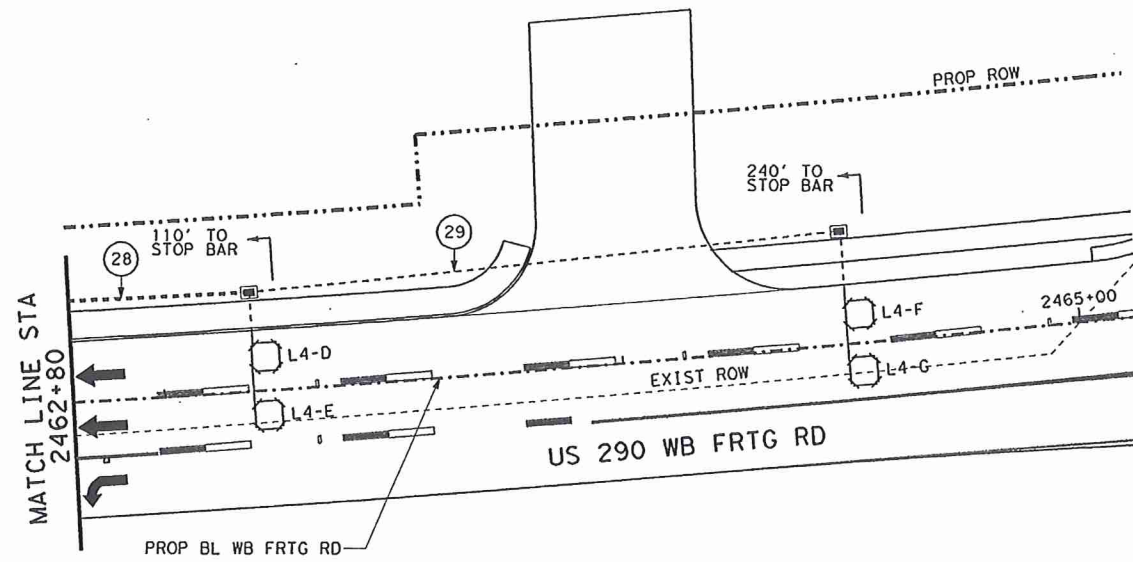

THE SEAL APPEARING ON THIS DOCUMENT WAS AUTHORIZED BY DALE H. HILLIARD, P.E. 70892 ON 5/21/2012

Dale H. Hilliard



REV. NO.	DATE	DESCRIPTION	BY
EXCELSIS, INC. CONSULTING ENGINEERS 2825 WILCREST DR, SUITE 100 HOUSTON, TEXAS 77042 <small>TBPE NO. F-731</small>			
US 290 PROPOSED TRAFFIC SIGNAL LAYOUT FM 529			
SHEET 3 OF 3			
DSH#	FED. RD. DIV. NO.	STATE	PROJECT NO.
CR#	6	TEXAS	US 290
DR#	STATE DISTRICT	COUNTY	CONTROL SECTION JOB SHEET NO. NO. NO.
CR#	HOU	HARRIS	0050 09 071, ETC 2045

DESIGN SPEED LIMIT ON US 290 FRONTAGE RD 40 MPH

approve

5/21/2012 10:11:24 AM ...SHEET FILES\SIC\0715DPO3.dgn